

Introduction:

Like spice, its diminutive size is a stark contrast to its standout performance in terms of brightness, durability and reliability. Despite being the smallest in size yet the SpicePlus 2520 packs a powerful performance and is a highly reliable design device.



Features:

- > Super high brightness surface mount LED automotive exterior applications.
- > 120° viewing angle.
- > Compact package outline (LxW) of 2.5 x 2.0mm.
- > Ultra low height profile - 0.7mm.
- > Low thermal resistance.
- > Superior corrosion robustness.
- > Compatible to IR reflow soldering.
- > Compliance to automotive standard; AEC-Q101.
- > Environmental friendly; RoHS compliance

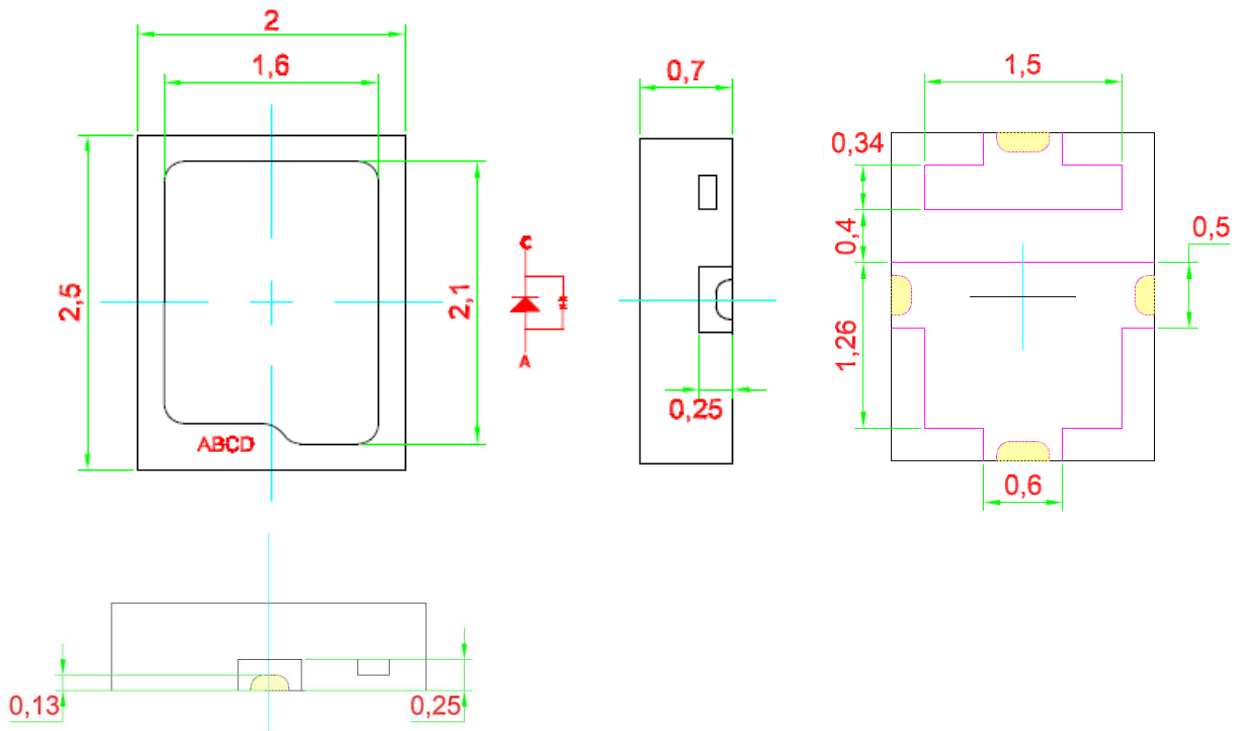

Note : Primary thermal path is through Anode lead of LED package
General Tolerances ± 0.10

Figure 1: SpicePlus 2520 package dimension

Standard Soldering Process:

The SpicePlus 2520 soldering surfaces are plated with gold (Au) and are therefore RoHs compliant. The component is designed to be compatible to the existing industry SMT process and IR-reflow. There are no special processes or equipment required for the mounting of the components onto applications. Both the thermal and electrical connections are provided by the conventional process. Therefore, there is no need to provide for additional process or material to take care for the thermal connection.

However, due to the unique design, all the soldering terminals are located at the bottom surface of the component. This greatly reduces the space required and also enhances the thermal dissipation capability of the component. Heat from the LED chip is directly conducted via the soldering terminals to the external environment. Thermal path is kept to the very minimum.

As for the soldering process, the component is qualified for Pb-free soldering profile. The profiles is as per described in the datasheet.

Recommended Pb Free IR-Reflow Soldering Profile

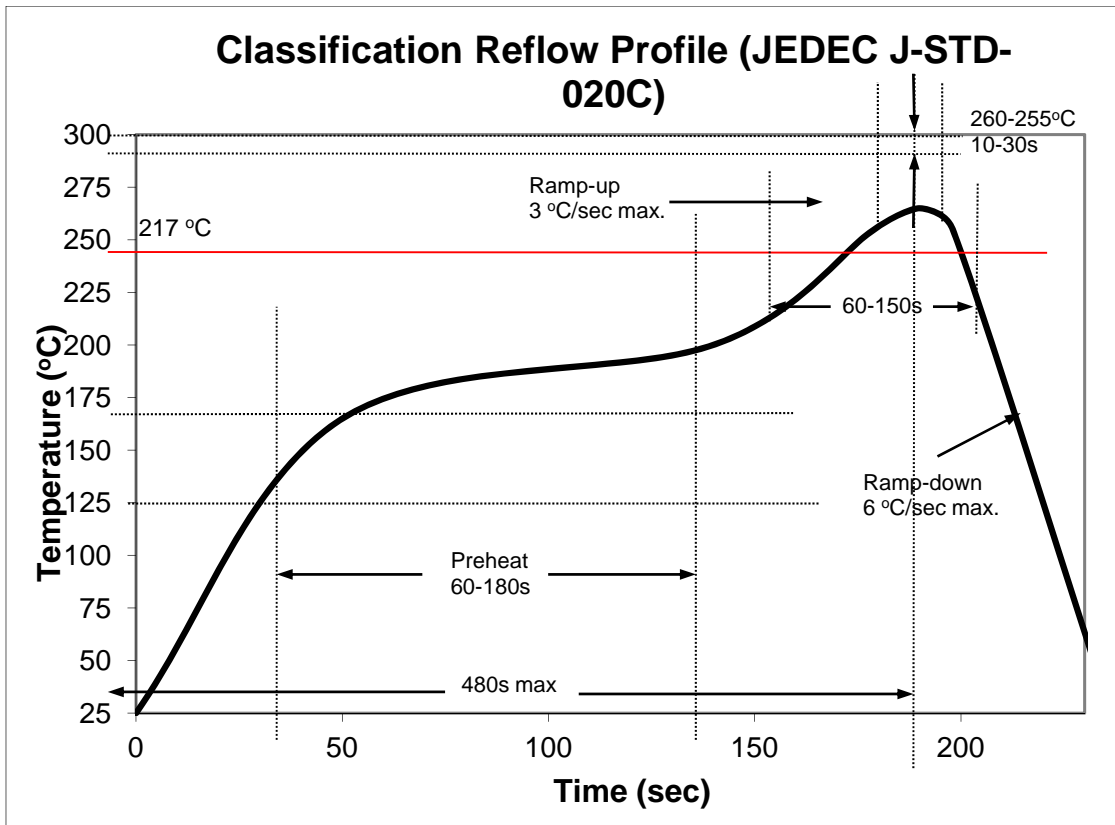

Surface Mounting – Factors to Consider:

This application note provides a guideline for the surface mounting of SpicePlus 2520. The following parameters have to be considered in order to optimize the surface mounting performance.

- > Solder pad size
- > Solder stencil size
- > Pipette (nozzle)
- > Placement force
- > Solder paste thickness

Solder Pad Size

The recommended solder pad design is as illustrated below

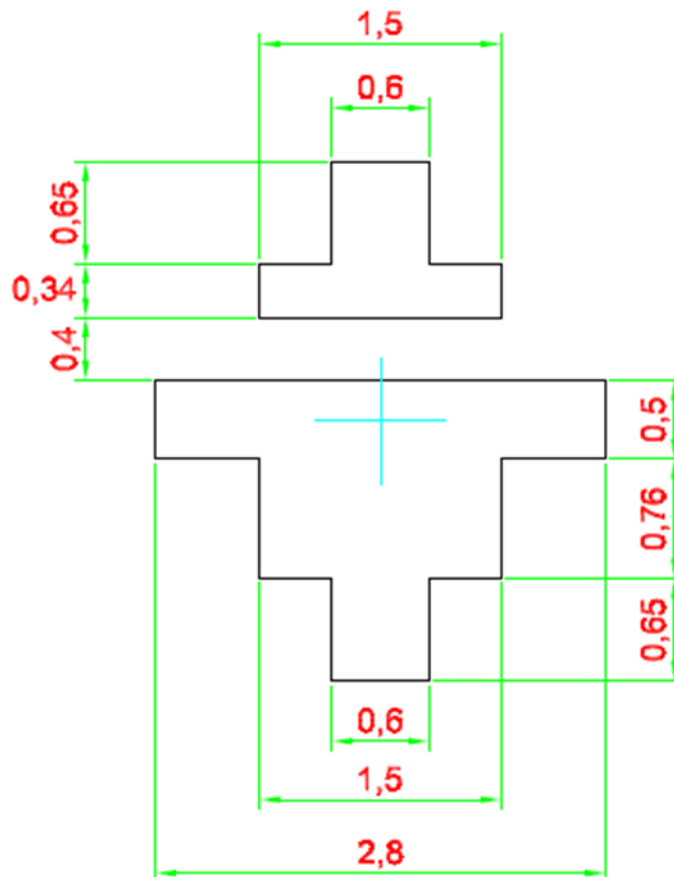

For SpicePlus 2520 package, the primary thermal path is through the anode lead of the LED package. Copper coverage area on PCB board can be extended beyond the anode solder pad in order to improve heat dissipation.

SpicePlus 2520 Solder Stencil Design:

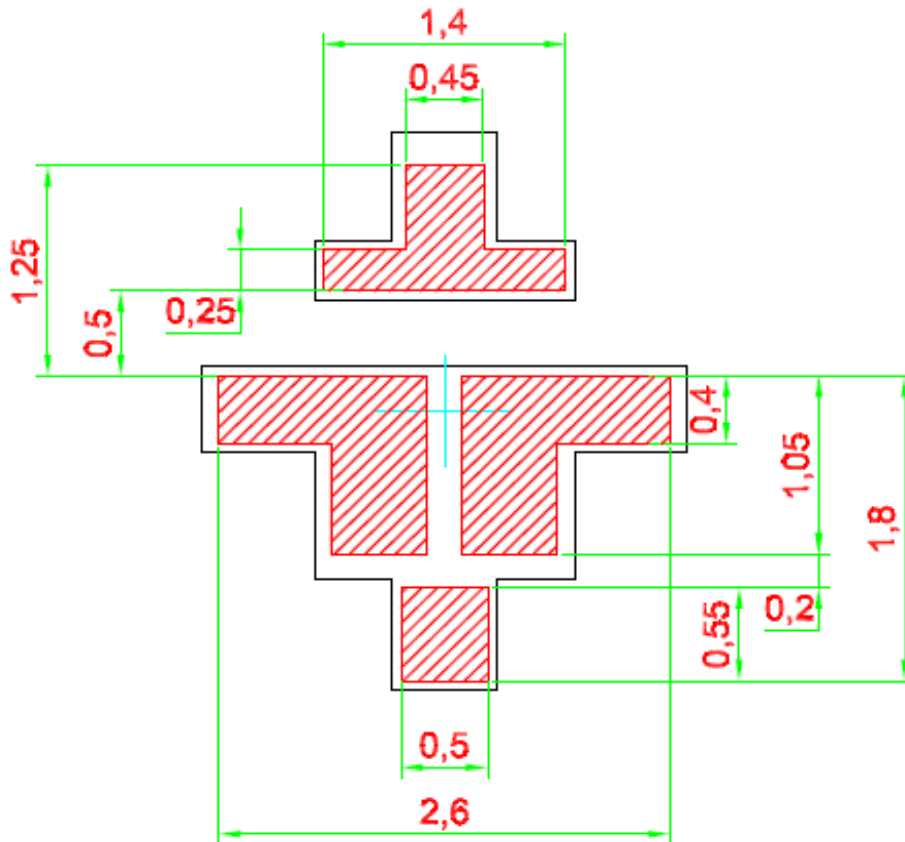

In order to minimize solder bridging problems, it is common to design stencil aperture size smaller than the recommended solder pad. Excessive amount of solder paste deployed will result to tilted parts and inaccurate placement position. It is recommended that the aperture is reduced to 75% of the recommended solder pad design.

Pipette

Pick and place machine should be able to process SpicePlus 2520 devices with the required placement accuracy. Care should be observed that the surface of the pipette which is in contact with the LED is flat and smooth. The pick and place nozzle use must be bigger than the LED emission area. This would prevent LED from sticking to the pick and place nozzle. Parameter settings for the pick and place process should also be evaluated to ensure no damage to the LEDs.

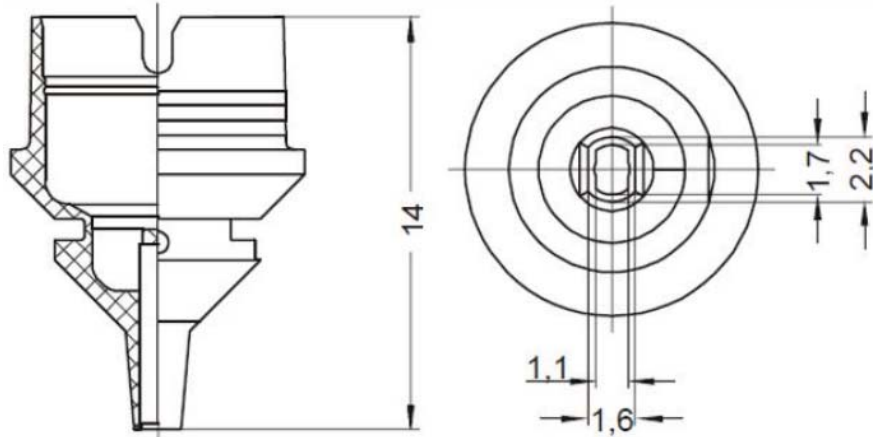

Figure 2: Pick & Place Nozzle

Placement Force

To avoid any damage to our LED package, all pick and place process parameters including placement force parameter should be controlled and adjusted during the setup. The recommended placement force is 0.5N. The maximum placement force should be controlled at less than 1.6N (Based on Panasonic NPM series SMT Mounter). This placement force is SMT machine model dependent. Customer should validate this parameter during initial product qualification phase to ensure optimum setting & to prevent LED damage.

Solder Paste Thickness

We recommend using minimum solder paste in order to achieve a good solder formation. A solder paste/solder stencil thickness of 0.125 mm will be optimum.

Solder Wetting Check after SMT Process

For SpicePlus 2520 LED, there are four solder tunnels with Gold (Au) plating. The purpose is for solder wetting check after SMT process.

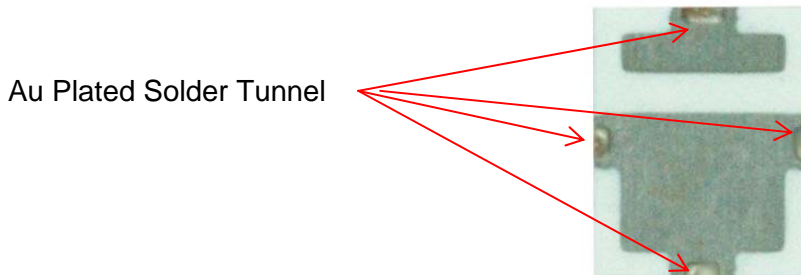

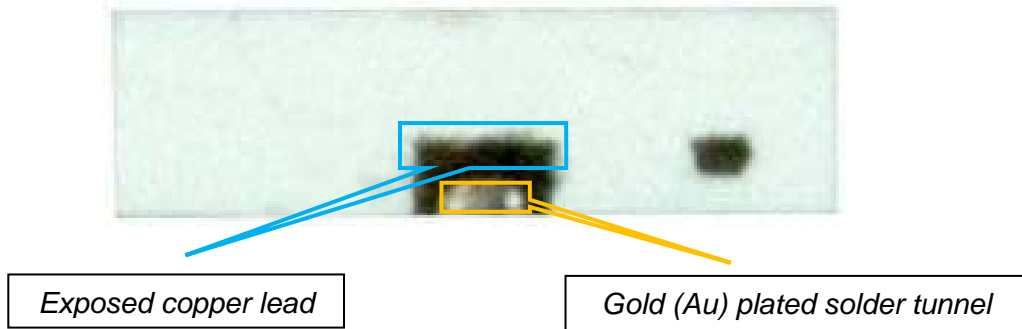

SpicePlus 2520 LED side view

The solder tunnel which is plated with gold (Au) will have excellent solderability and solder fillet can be observed at this section after SMT process. Sections which are exposed copper remained from the lead frame trim and form process around solder tunnel that are not plated with gold will only be partially solderable. Anyway this feature will not impact the product quality & reliability in any aspect.

Solder formation at the side of SpicePlus 2520 LED

