

**Introduction:**

**THE NEEDS OF A CONTROLLED CURRENT SOURCE**

The IV curve for LED is similar to the IV curve for normal diode, except that it has steeper slope of  $I_f$  versus  $V_f$  in the high current region. As an example from the figure 1 below, variation of 0.1V supply voltage will cause the forward current differs by approximately 50mA. Since the luminous intensity of LED varies with forward current, this causes the relative intensity to vary by >10%. Therefore, LED circuitry should be designed to drive by controlled current source rather than controlled voltage source. With rapid advancement in semiconductor technology, various IC component suppliers are capable of producing constant current LED driver with output current accuracy  $\pm 3.5\%$  between drivers and current matching smaller than 0.5% within driver ( for LED driver with more than 1 output channel drive).

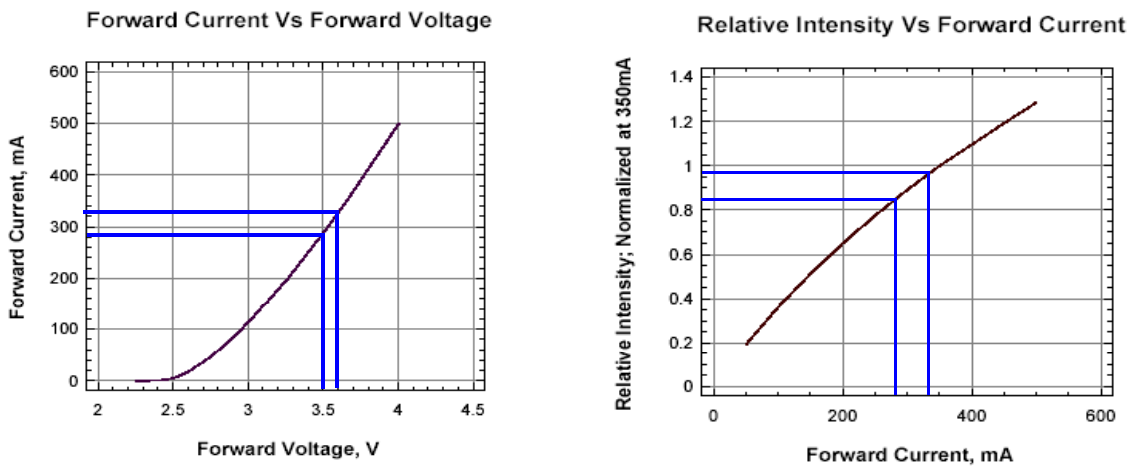

**Figure 1– SPNovaLED InGaN White 350mA  $I_f$  vs  $V_f$  and  $I_v$  vs  $I_f$  Characteristic**

**GENERAL LED CIRCUIT DESIGN OVERVIEW**

<b>Current Limiting Method</b>	<b>Advantage</b>	<b>Disadvantage</b>
Resistor ( most common in existing automotive circuit design )	<ul style="list-style-type: none"> <li>• Easy to design.</li> <li>• Inexpensive.</li> </ul>	<ul style="list-style-type: none"> <li>• It cannot control current accurately.</li> <li>• Current varies to some extent with supply voltage.</li> <li>• High power dissipation in the resistor especially on high power LED.</li> </ul>
Linear Current Regulator	<ul style="list-style-type: none"> <li>• Allow dimming through current control.</li> <li>• Linear control-loop circuitry accurately controlled the LED current.</li> </ul>	<ul style="list-style-type: none"> <li>• More expensive than simple resistive current limiter.</li> <li>• High power dissipation.</li> <li>• Might require heat sink for active pass device.</li> </ul>
Switching Regulator Control	<ul style="list-style-type: none"> <li>• Efficient operation over wide range of input voltage.</li> <li>• Able to regulate LED current precisely.</li> <li>• Allow dimming by PWM.</li> <li>• Lower power dissipation.</li> </ul>	<ul style="list-style-type: none"> <li>• More complex design.</li> <li>• More expensive compare to linear current supply.</li> <li>• Need to design for electromagnetic compatibility.</li> </ul>

**Current Limiting Method : Resistor**

**Series LED Drive Configuration :**



**Pros :**

- Matching guaranteed with well regulated LED current
- Easy implementation with inductive boost
- Only 1 ballast element, most power efficient, ballast loss =  $V_{Ballast} \times I_{LED}$

**Cons :**

- High output voltage drive required for long string of series LED. For low input voltage application, boost type regulator might be required
- A single defective LED would cause the whole string to fail

**Parallel LED Drive Configuration :**

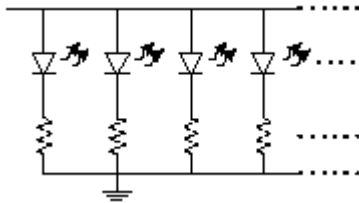

**Pros :**

- Single defective LED will not cause all LED network to fail
- Lower output voltage drive required

**Cons :**

- Require regulated current source to ensure good matching, 1 for each LED
- More power loss compare to series implementation.  
 Total ballast loss =  $N \times V_{Ballast} \times I_{LED}$

**Parallel Strings of LEDs Configuration :**

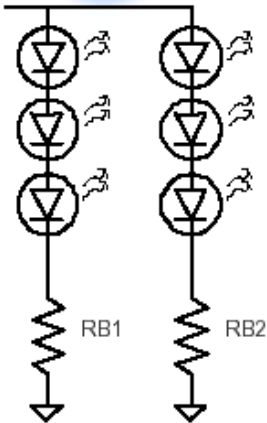

**Pros :**

- Good for driving lots of LEDs
- Reduce the output voltage drive requirement compare to the series implementation for the same LED count.
- Lower power loss ( ballast loss ) compare to pure parallel implementation for the same LED count.

**Cons :**

- Only the 1<sup>st</sup> string has regulated current. Diode voltages set the current for all secondary strings.
- LED voltage mismatches would lead to brightness difference from one string to another.

**Current Limiting Method : Linear Current Regulator**

Figure 2, a typical LED circuit design using linear current regulator NUD4001 produce by On Semiconductor.

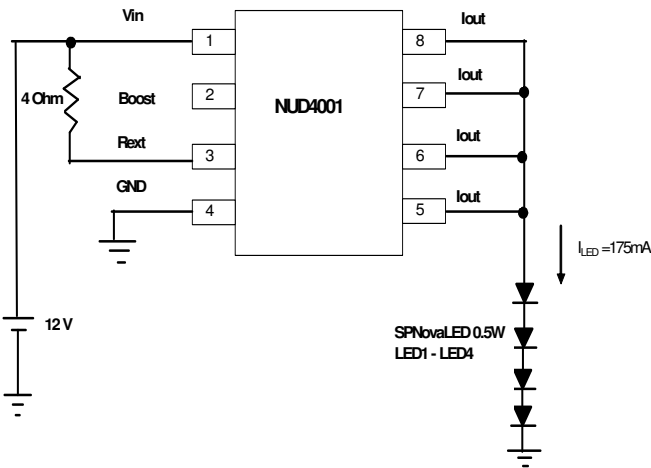

**Features :**

- Up to 30V operating range
- Adjustable output current level up to 500mA
- Minimum component count
- Suitable for automotive application in tail light, CHMSL and internal lighting application

**Figure 2 – On Semiconductor NUD4001 linear current regulator**

## **Current Limiting Method: Switching Regulator Control**

### **A. SWITCHING POWER SUPPLY CURRENT CONTROL DRIVER**

With ever demanding for higher brightness LED and higher power efficiency especially for portable power application, there is trend for major IC component manufacturer to introduce more advance switching LED current control driver with various functionality and better current matching/regulation.

When choosing the switching power supply LED current control driver, consideration should be taken on the supply input voltage level versus the output LED load voltage level. Basically the are 3 type of topologies for switching power supply :

- 1. Buck Regulator**  
It can function if the input voltage always exceeds the sum of the maximum forward voltages of every LED in a string. It can reduce the output voltage to a lower level to minimize power loss.
- 2. Boost Regulator**  
When the sum of all the forward voltages drop in a string will always exceed the maximum input voltage, a boost regulator is needed to amplify the output voltage to the required range in order to drive the LED network.
- 3. Buck/Boost Regulator**  
When the input voltage might swing above or below the sum of all the forward voltage drop in a string, then a buck/boost regulator should be use to drive the LED network.

Various LED driving circuitry is depicted as below, please refer to respective IC manufacturer for detail design consideration when using their LED driver.

**Switching Buck Regulator**

Figure 3, a high power LED driving circuit design using National Semiconductor LM3402 0.5A constant current buck regulator.  $V_{in}$  range from 6V to 42V ( LM3402 ).

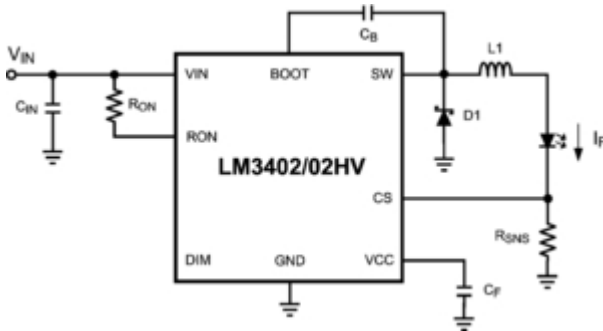

**Figure 3 – LM3402, an example of buck regulator**

Figure 4, another LED circuit design using Texas Instrument bq24105. The bqSWITHER series can achieve 10% current regulation accuracy for 100mV to 200mV sensing resistor voltage.

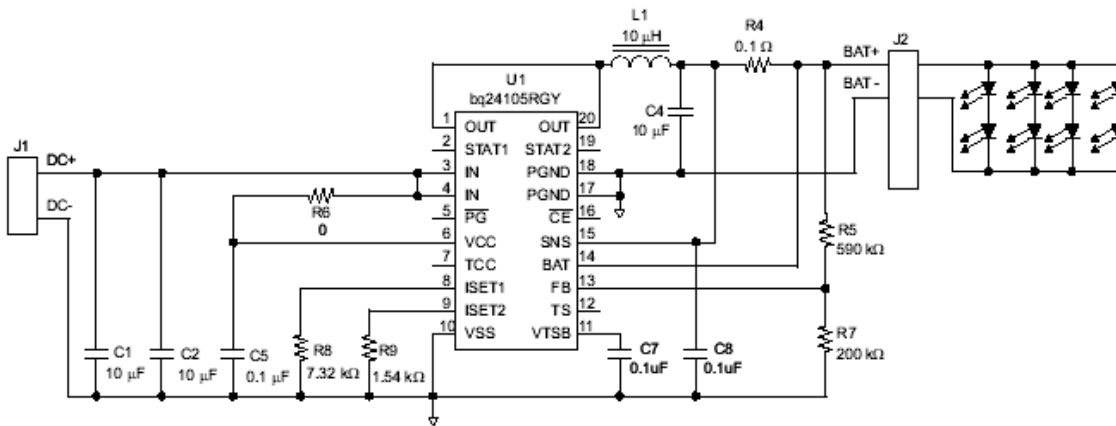

**Figure 4 – bq24105, an example of buck regulator**

A list of market commonly available buck regulator is as tabulated below :

Type	Supplier	Part Number	Vin (DC)	Vout(max, DC)	Iout (max, mA)
Buck	<a href="#">Exar</a>	SP6652	2.7 to 5.5	5	1000
	<a href="#">Exar</a>	SP6655	2.7 to 5.5	5	400
	<a href="#">STMicroelectronics</a>	L6926	2 to 5.5	5	800
	<a href="#">Melexis</a>	MLX10803	6 to 32	32	External
	<a href="#">National Semiconductor</a>	LM3401	4.5 to 35	35	External
	<a href="#">National Semiconductor</a>	LM3407	4.5 to 30	27	350
	<a href="#">National Semiconductor</a>	LM3402	6 to 42	41	500
	<a href="#">National Semiconductor</a>	LM3402HV	6 to 75	74	500
	<a href="#">National Semiconductor</a>	LM3404	6 to 42	41	1200
	<a href="#">National Semiconductor</a>	LM3406	6 to 42	37	1500
	<a href="#">National Semiconductor</a>	LM3406HV	6 to 75	67	1500
	<a href="#">National Semiconductor</a>	LM3405A	3 to 22	21	1000
	<a href="#">National Semiconductor</a>	LM3404HV	6 to 75	74	1500
	<a href="#">National Semiconductor</a>	LM3489	4.5 to 35	Adjustable	External
	<a href="#">Sipex</a>	SP6137	3 to 20	3 to 15	External
	<a href="#">STMicroelectronics</a>	L6902	8 to 36	34	1000
	<a href="#">Zetex</a>	ZXLD1350E5	9 to 30	30	350
	<a href="#">Zetex</a>	ZXLD1350	7 to 30	30	350
	<a href="#">Zetex</a>	ZXLD1360	7 to 30	30	1000
	<a href="#">Zetex</a>	ZXLD1362	6 to 60	60	1000
	<a href="#">Zetex</a>	ZXLD1320	4 to 18	18	1500
	<a href="#">Zetex</a>	ZXLD1352	7 to 30	30	350
	<a href="#">Zetex</a>	ZXLD1356	6 to 60	60	550
	<a href="#">Zetex</a>	ZXLD1366	6 to 60	60	1000
	<a href="#">National Semiconductor</a>	LM2734	3 to 20	18	1000
	<a href="#">Sipex</a>	SP7601	4.5 to 29	29	External
	<a href="#">Catalyst</a>	CAT4201	6.5 to 20	32	350

**Switching Boost Regulator**

Figure 5 below shows a typical switching boost regulator circuit design using Linear Technology LT3466-1, white LED driver and boost converter. It can drive up to 10 white LEDs from a 3.6V supply. It allows +4% current programming accuracy.

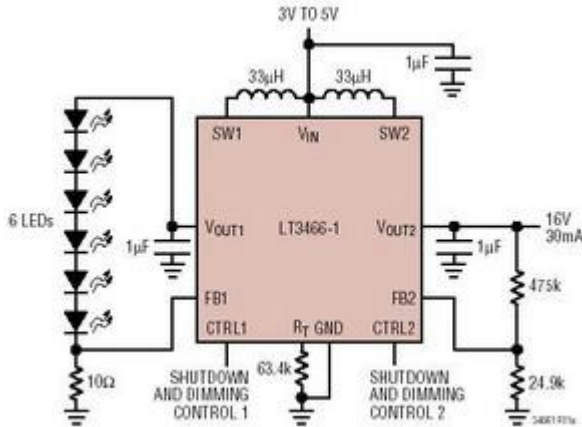

**Figure 5—LT3466-1, an example of boost regulator**

Figure 6, another switching boost regulator design using On Semiconductor NCP5010, 500mW boost converter for white LED. It featuring 2.7V to 5.5V input voltage range. 84% Efficiency for 5 LEDs at 30mA and  $V_{in} = 4.2V$

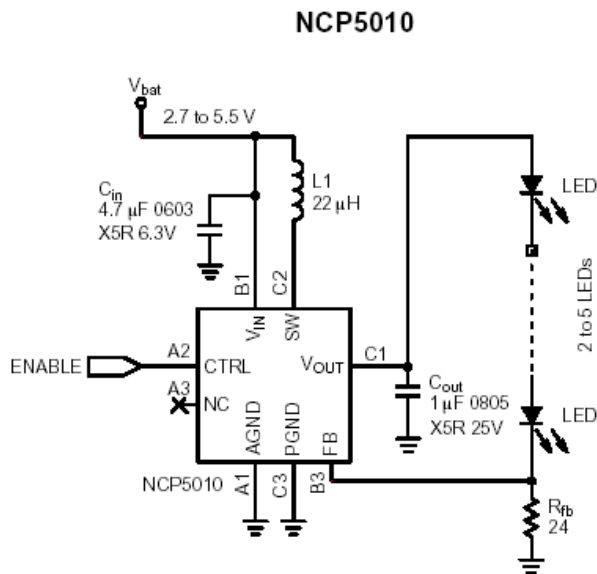

**Figure 6—NCP5010, an example of boost regulator**

A list of market commonly available boost regulator is as tabulated below :

Type	Supplier	Part Number	Vin (DC)	Vout(max, DC)	Iout (max, mA)
Boost	<a href="#">ON Semiconductor</a>	NCP1422	1.0 to 5.0	5	800
	<a href="#">ON Semiconductor</a>	NCP1450A	0.8 to 6.0	6	1000
	<a href="#">Exar</a>	SP6641B	1.0 to 5.0	6	500
	<a href="#">Exar</a>	SP6648	0.7 to 4.5	4	400
	<a href="#">Exar</a>	SP7648	2.7 to 4.5	2.7 to 5.5	800
	<a href="#">Zetex</a>	ZXSC310E5	0.8 to 8.0	8	1100
	<a href="#">Zetex</a>	ZXSC400E6	1.8 to 8.0	8	1100
	<a href="#">Zetex</a>	ZXLD1321	1.2 to 12.0	18	1000
	<a href="#">National Semiconductor</a>	LM2623A	0.8 to 14	14	1000
	<a href="#">National Semiconductor</a>	LM2700	2.2 to 12	17.5	1000
	<a href="#">National Semiconductor</a>	LM3551	2.7 to 5.5	11	1000
	<a href="#">National Semiconductor</a>	LM3553	2.7 to 5.5	19	1200
	<a href="#">STMicroelectronics</a>	L6920	0.6 to 5.5	8	500

### Switching Buck/Boost Regulator

Figure 7 below shows a typical switching buck/boost regulator circuit design using Linear Technology LTC3453, Synchronous Buck Boost High Power White LED Driver. It is optimized to drive up to 4 white LEDs at a combined current of 500mA from a single Li-Ion battery input. The regulator operates in either buck, boost or buck-boost mode, depending on the input voltage and LED maximum forward voltage.

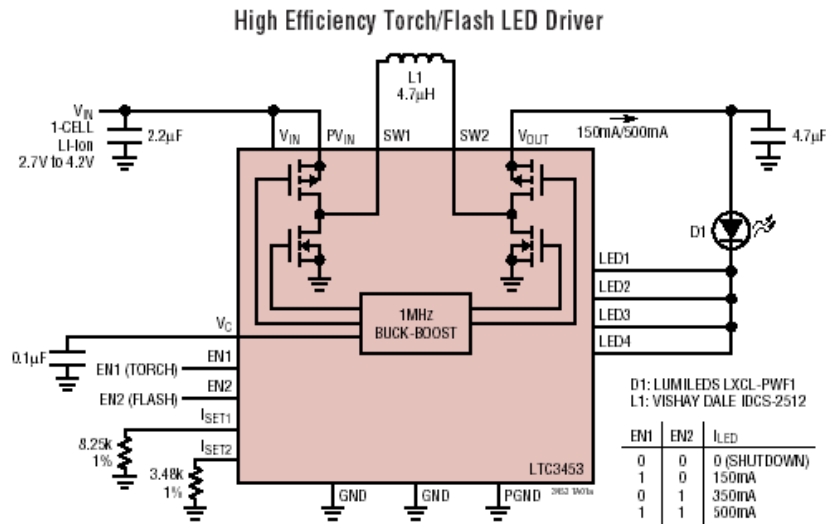

**Figure 7-- LTC3453, an example of buck/boost topology regulator**

Figure 8, another switching buck-boost regulator circuit design using MAXIM MAX1759, Buck-Boost Charge Pump Regulator. In the design below, the regulator biases white LEDs with 15mA current from a wide 1.6V to 5.5V voltage range.

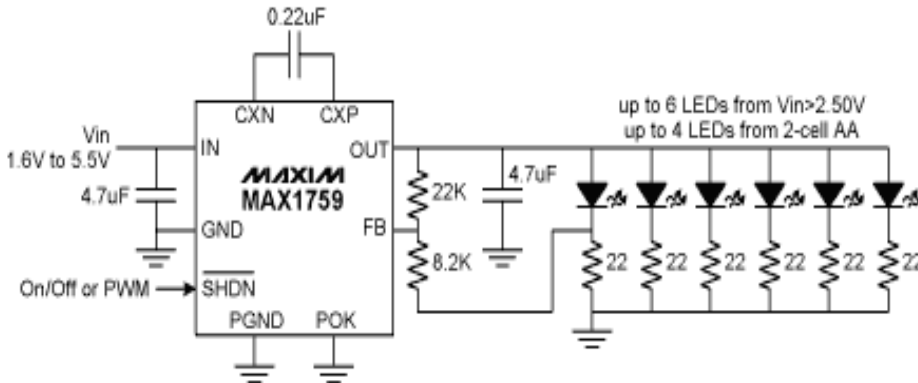

**Figure 8—MAX1759, an example of buck/boost topology regulator**

A list of market commonly available buck/boost regulator is as tabulated below:

Type	Supplier	Part Number	Vin (DC)	Vout(max, DC)	Iout (max, mA)
<b>Buck/Boost</b>	<a href="#">STMicroelectronics</a>	STCF02	2.7 to 5.5	2.5 to 5.3	600
	<a href="#">STMicroelectronics</a>	STCF03	2.7 to 5.5	2.5 to 5.3	800
	<a href="#">Zetex</a>	ZXLD1322	2.5 to 15.0	15	700
	<a href="#">ON Semiconductor</a>	NCP5030	2.7 to 5.5	5.5	1200
	<a href="#">ON Semiconductor</a>	NCP3163	2.5 to 40	40	3000
	<a href="#">ON Semiconductor</a>	NCP3065	3.0 to 40	40	1500
	<a href="#">National Semiconductor</a>	LM3423	4.5 to 75	75	External
	<a href="#">National Semiconductor</a>	LM3421	4.5 to 75	75	External
	<a href="#">Zetex</a>	ZXLD1322	2.5 to 15	15	700

**B. ADVANCE LIGHT MANAGEMENT UNIT (ALMU)**

With the increasing popularity of LED application in various fields, especially in mobile handheld application and display backlighting, several major integrated circuit supplier have already starts to produce the advance light management IC. This ALMU not only regulate the LED current, but also provide various functionality to manage the brightness, sequence, and to synchronize the LEDs with audio input. The ALMU usually will come with an I<sup>2</sup>C or SPI interface. This ALMU will further reduce the space required for LED control circuit and will simplify the circuit design effort. Several examples are depicted below. Please consult respective IC manufacturer’s website for detail information.

National Semiconductor, LP3954, Advance Light Management Unit

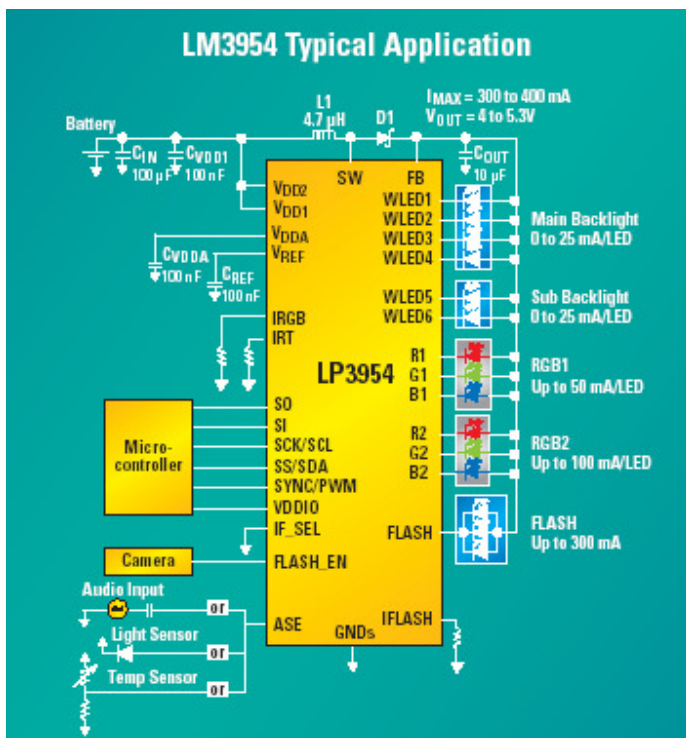

**Features :**

- Advance Light Management Unit for handheld product
- Audio synchronization for color/RGB LEDs
- High current driver for flash LED with built-in timing
- Six constant current white LED driver with 8-bit programmable adjustment
- SPI/I<sup>2</sup>C compatible interface
- Possibility for external PWM dimming control

**Figure 9—LP3954 Advance Light Management Unit**

**MAXIM MAX1707, Light Management Unit**

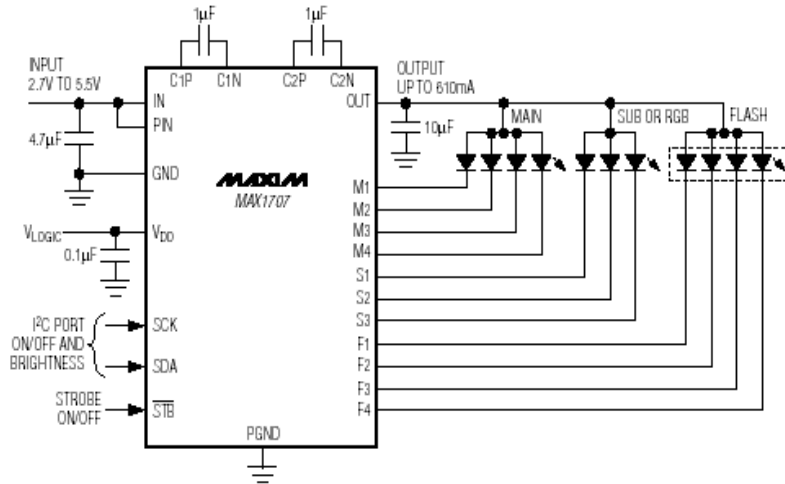

**Figure 10 – MAX1707 Light Management Unit**

**Features :**

- The MAX1707 provides complete light management for main display backlight, sub-display backlight and white LED camera flash with regulated constant current up to total 610mA.
- An I2C serial port is used for on/off control and setting the LED currents in 32 linear steps.
- 0.3% LED current accuracy and matching.
- The I2C port provides 32k colors and programmable ramp up/down rates.
- The camera flash may be turned on/off by the I2C port

## LED CIRCUIT PRACTICAL DESIGN GUIDE

For automotive/general lighting application, the most common input supply voltage would be 12V & 24V DC. The most common LED drive current level would be 120mA -150mA for SPNovaLED 0.5Watt and 320mA - 350mA for SPNovaLED 1Watt.

Two examples of reference design to drive a series of LEDs at  $V_{in} = 12V$ , using On Semiconductor NUD4001, High Current LED Driver is depicted below. Please refer to NUD4001 datasheet for further technical details.

**Reference Design 1 :** Driving 4 Series Connected SPNovaLED 0.5Watt At Forward Current of 150mA , Supply Voltage,  $V_{in} = 12V$

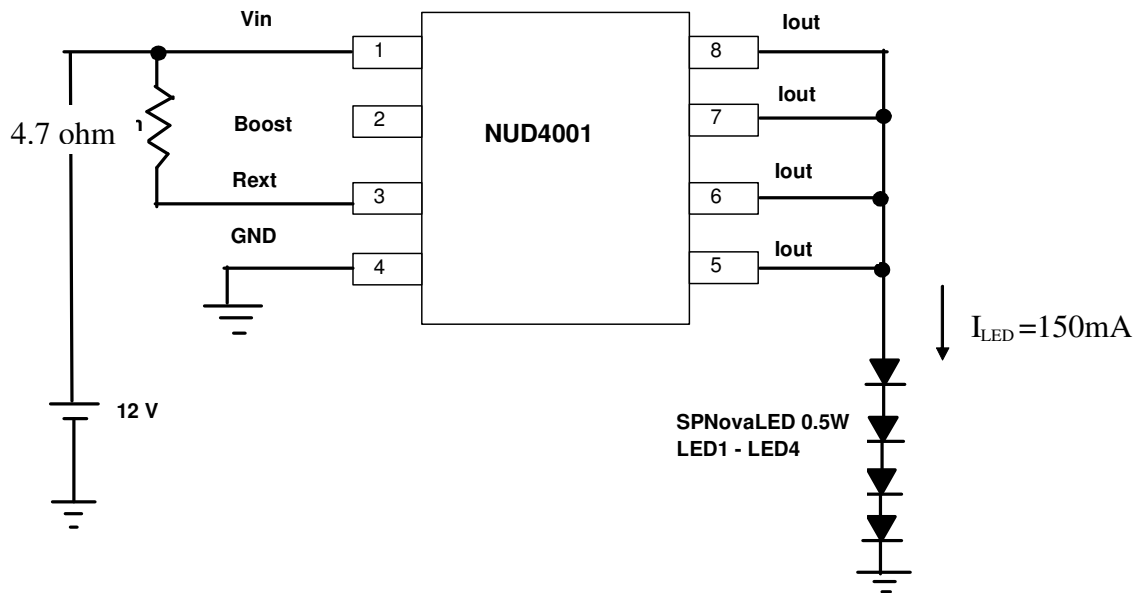

Bill Of Materials:

Part	Manufacturer	Part Number	Attribute
$R_{ext}$	Vishay	CRA06E0803472JRT1	4.7 Ohm resistor
NUD4001	On Semiconductor	NUD4001DR2G	High Current LED Driver
LED1-LED4	Dominant Semiconductor	NPR-SSS-XY2-1	SPNovaLED 0.5W Red

Several key parameters for NUD4001 are as follow :

1.  $V_{sense} = 0.7\text{ V}$  at  $T_j = 25\text{ }^\circ\text{C}$
2.  $P_{D\_control}$ , Power dissipation for internal circuitry of NUD4001 is 0.055W at 12V input, 0.25W at 24V input.
3. Maximum power dissipation of NUD4001 is 1.13W.
4. It supplies constant LED current for varying input voltage up to 30V max
5. Output current level is defined by the resistor,  $R_{ext}$

**Electrical Design Guide:**

1. LED current required,  $I_{LED}$  is 150mA
2. Resistor value for  $R_{ext} = V_{sense} / I_{LED} = 0.7\text{V}/0.150\text{ Ohm} = 4.7\text{ Ohm}$

**Thermal Design Guide :**

Base on Dominant Semiconductor datasheet for SPNovaLED, for example NPY-SSS-XY2, the minimum forward Voltage  $V_{fmin} = 1.9\text{V}$ , typical forward voltage  $V_{ftyp} = 2.2\text{V}$ . The power dissipation in the current regulator IC should be calculated for  $V_{fmin}$ , where the voltage drop across the current driver would be maximum. This will prevent the NUD4001 from being killed due to overheat.

$V_{fmin} = 1.9\text{V}$	$V_{ftyp} = 2.2\text{V}$
Total voltage across LED, $V_{LED} = 1.9\text{V} \times 4 = 7.6\text{V}$	$V_{LED} = 2.2\text{V} \times 4 = 8.8\text{V}$
Voltage drop across NUD4001, $V_{drop} = V_{in} - V_{sense} - V_{LED}$ $= 12\text{V} - 0.7\text{V} - 7.6\text{V}$ $= 3.7\text{V}$	$V_{drop} = 12\text{V} - 0.7\text{V} - 8.8\text{V}$ $= 2.5\text{V}$
Power dissipation across NUD4001, $PD_{driver} = V_{drop} \times I_{out}$ $= 3.7\text{V} \times 0.175\text{A}$ $= 0.6475\text{W}$	$PD_{driver} = 2.5\text{V} \times 0.175\text{A}$ $= 0.4375\text{W}$
Total power dissipation, $PD_{total} = PD_{driver} + PD_{control}$ $= 0.6475\text{W} + 0.055\text{W}$ $= 0.7025\text{W}$	$PD_{total} = 0.4375\text{W} + 0.055\text{W}$ $= 0.4925\text{W}$

Base on both case of Vf above, the total power dissipation is < 1.13W, which means the circuit above can be operated without overheating the NUD4001.

**Reference Design 2 : Driving 3 Series Connected SPNovaLED 1 Watt At Forward Current of 350mA , Supply Voltage,  $V_{in} = 12V$**

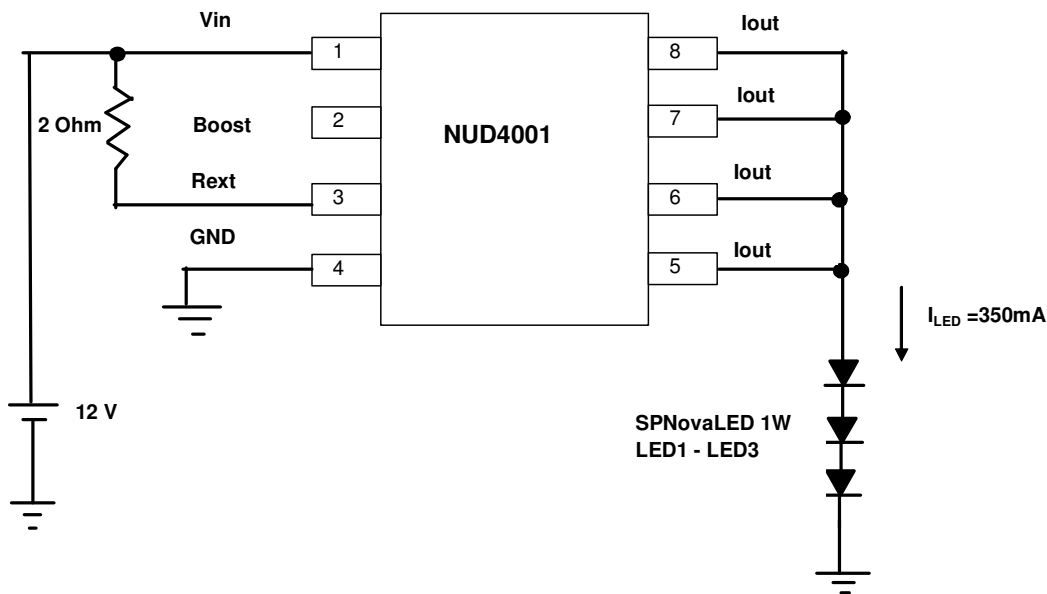

**Bill Of Materials:**

Part	Manufacturer	Part Number	Attribute
$R_{ext}$	Vishay	CRCW12062R00FRT1E3	2 Ohm resistor
NUD4001	On Semiconductor	NUD4001DR2G	High Current LED Driver
LED1-LED3	Dominant Semiconductor	NPW-USD-AD-1	SPNovaLED 1W White

Several key parameters for NUD4001 are as follow :

1.  $V_{sense} = 0.7 V$  at  $T_j = 25 \text{ Deg C}$
2.  $P_{D\_control}$ , Power dissipation for internal circuitry of NUD4001 is 0.055W at 12V input, 0.25W at 24V input.
3. Maximum power dissipation of NUD4001 is 1.13W
4. It supplies constant LED current for varying input voltage up to 30V max
5. Output current level is defined by the resistor,  $R_{ext}$

**Electrical Design Guide:**

1. LED current required,  $I_{LED}$  is 350mA
2. Resistor value for  $R_{ext} = V_{sense} / I_{LED} = 0.7V / 0.350 \text{ Ohm} = 2 \text{ Ohm}$

**Thermal Design Guide :**

Base on Dominant Semiconductor datasheet for SPNovaLED, NPW-USD-AD-1, the minimum forward Voltage  $V_{f_{min}} = 3.0V$ , typical forward voltage  $V_{f_{typ}} = 3.6V$ .

<b><math>V_{f_{min}} = 3.0V</math></b>	<b><math>V_{f_{typ}} = 3.6V</math></b>
Total voltage across LED, $V_{LED} = 3.0 V \times 3 = 9.0V$	$V_{LED} = 3.6V \times 3 = 10.8V$
Voltage drop across NUD4001, $V_{drop} = V_{in} - V_{sense} - V_{LED}$ $= 12V - 0.7V - 9.0V$ $= 2.3V$	$V_{drop} = 12V - 0.7V - 10.8V$ $= 0.5V$
Power dissipation across NUD4001, $PD_{driver} = V_{drop} \times I_{out}$ $= 2.3V \times 0.350A$ $= 0.805W$	$PD_{driver} = 0.5V \times 0.350A$ $= 0.175W$
Total power dissipation , $PD_{total} = PD_{driver} + PD_{control}$ $= 0.805W + 0.25W$ $= 1.055W$	$PD_{total} = 0.175W + 0.25W$ $= 0.425W$

Base on both case of Vf above, the total power dissipation is < 1.13W, which means the circuit can be operated without overheating the NUD4001.

Please note that for the both reference design above, care should be taken to ensure minimum input voltage,  $V_{in_{min}} > V_{sense} + V_{LED(Max)}$  , in order to supply enough forward voltage drive for the LEDs.

**Reference Design 3:** Using National Semiconductor LM3402 ( 0.5A Constant Current Buck Regulator ).

Driving 6 Series Connected SPNovaLED 1 Watt at Forward Current of 330mA, Supply Voltage,  $V_{in} = 24V$  ( Please refer to National Semiconductor LED Reference Design Library : <http://www.national.com/webench/ledrefdesigns.do> for further details and circuit simulations. )

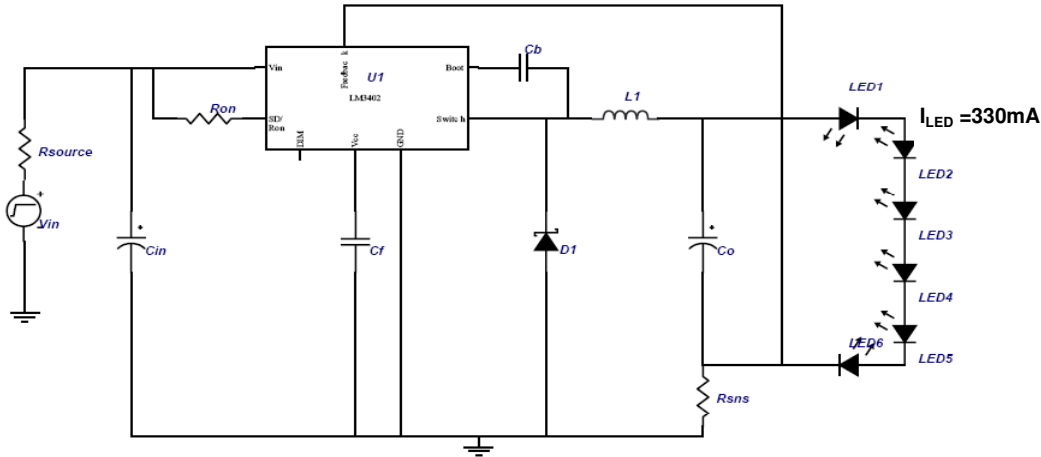

Bill Of Materials:

Part	Manufacturer	Part #	Value
Cb	Vishay	VJ0805Y103KXXAT	10nF
Cf	Vishay	VJ0805Y104KXXAT	100nF
Cin	TDK	C3225X7R1H225M	2.2uF
Co	TDK	C3225X7R1E475M	4.7uF
D1	Central Semiconductor	CMSH1-40M	0.5V
L1	TDK	SLF7045T-470MR75	47uH, 0.15 Ohm
Ron	Vishay	CRCW08054873F	487k Ohm
Rsns	Panasonic	ERJ6BQFR56V	0.56 Ohm
U1	National Semiconductor	LM3402	
LED1-LED6	Dominant Semiconductor	NPW-TSD	SuperNovaLED 1 W

## **LED DRIVER**

The following is a list of integrated circuit suppliers that produce LED driver/LED Management device or regulator that can be configured to drive LED circuits. Please refer to their website for detail design consideration and specification. ( Note : The name of the IC manufacturers below is directly hyperlink to their respective website )

### **IC Supplier**

[Analog Devices](#)

[Fairchild Semiconductor](#)

[Holtek Semiconductor Inc.](#)

[Infineon](#)

[Intersil Corporation](#)

[Linear Technology](#)

[Maxim Integrated Products](#)

[Micrel Semiconductor](#)

[MICRO ANALOG SYSTEMS](#)

[MicroChip](#)

[Microsemi Corp.](#)

[Mitsubishi Semiconductor](#)

[National Semiconductor](#)

[SIPEX](#)

[SUPERTEX](#)

[STMicroelectronics](#)

[Texas Instruments](#)

[ZETEX](#)

With the rapid growth of LED industry, several premier analog IC suppliers have compiled a comprehensive LED driver guide for their products that would provide the designer with a vast choice of LED drivers based on their application needs. Four of the LED driver guide selections can be downloaded from the link below:

National Semiconductor :

[http://www.national.com/appinfo/power/files/lighting\\_solutions.pdf](http://www.national.com/appinfo/power/files/lighting_solutions.pdf)

Linear Technology :

<http://www.linear.com/> then select Power Management For LEDs

Arrow Electronics :

[http://www.arrow.com/industry\\_solutions/lighting/selector\\_guide.html](http://www.arrow.com/industry_solutions/lighting/selector_guide.html)

Supertex :

[http://www.supertex.com/products/selector\\_guides](http://www.supertex.com/products/selector_guides)

### **SUMMARY :**

To ensure good long-term reliability and brightness uniformity, the LED shall be driven by constant current source. Since there are a wide range of LED drivers available in the market from different electronic IC manufacturers, the implementation of constant current drive becomes very simple without the need of extensive circuit design while minimizing the total component count.