

Primax

Synonymous with function and performance, enter the Primax, the new era of high intensity illumination in LED. With its high flux output and high luminous intensity, Primax transcends today LED lightings technology and how we perceive it. The small package outline (3.7 x 3.5 x 0.8 mm) and high intensity make it an ideal choice for backlighting, signage, exterior automotive lighting and decorative lighting.



Features:

- > Super high brightness surface mount LED
- > 120° viewing angle.
- > Compact package outline (LxW) of 3.7 x 3.5 mm.
- > Ultra low height profile - 0.8mm.
- > Low thermal resistance.
- > Compatible to IR reflow soldering.
- > Environmental friendly; RoHS compliance.
- > Superior corrosion resistance.
- > Compliance to automotive standard; AEC-Q102.

Applications:

- > Automotive: Exterior application: eg: DRL (Day Running Light), Position Lamp, Backup Lamp, Side Marker.
Interior application: eg: Trunk Lamp, Reading Lamp, Map Lamp.

Optical Characteristics at Tj=25°C

Part Number	Color	Viewing Angle°	Luminous Flux @ 150mA (lm) <i>Appx. 1.2</i>		
			Min.	Typ.	Max.
MAW-SZHG-Q3S-L2P2	White	120	34.8	51.7	67.2
● MAW-SZHG-QS2-L1P2	White	120	30.6	45.0	59.0

● Not for new design.

Electrical Characteristics at Tj=25°C

Part Number	Vf @ If = 150 mA <i>Appx. 3.1</i>		
	Min. (V)	Typ. (V)	Max. (V)
MAW-SZHG	2.90	3.25	3.45

Absolute Maximum Ratings

	Maximum Value	Unit
DC forward current	200	mA
Peak pulse current (Ts=55 °C, tp ≤ 100µs, Duty cycle = 0.03)	300	mA
Reverse voltage	Not designed for reverse bias	V
ESD threshold (HBM)	8	kV
LED junction temperature	150	°C
Operating temperature	-40 ... +125	°C
Storage temperature	-40 ... +125	°C
Thermal resistance (Rated current = 150mA, Ts = 25°C)		
- Real Thermal Resistance		
Junction / solder point, R _{th JS real} (typ = 35)	45	K/W
- Electrical Thermal Resistance		
Junction / solder point, R _{th JS el} (typ = 25)	30	K/W

MAW-SZHG-Q3S-L2P2, Color Grouping *Appx. 2.1*

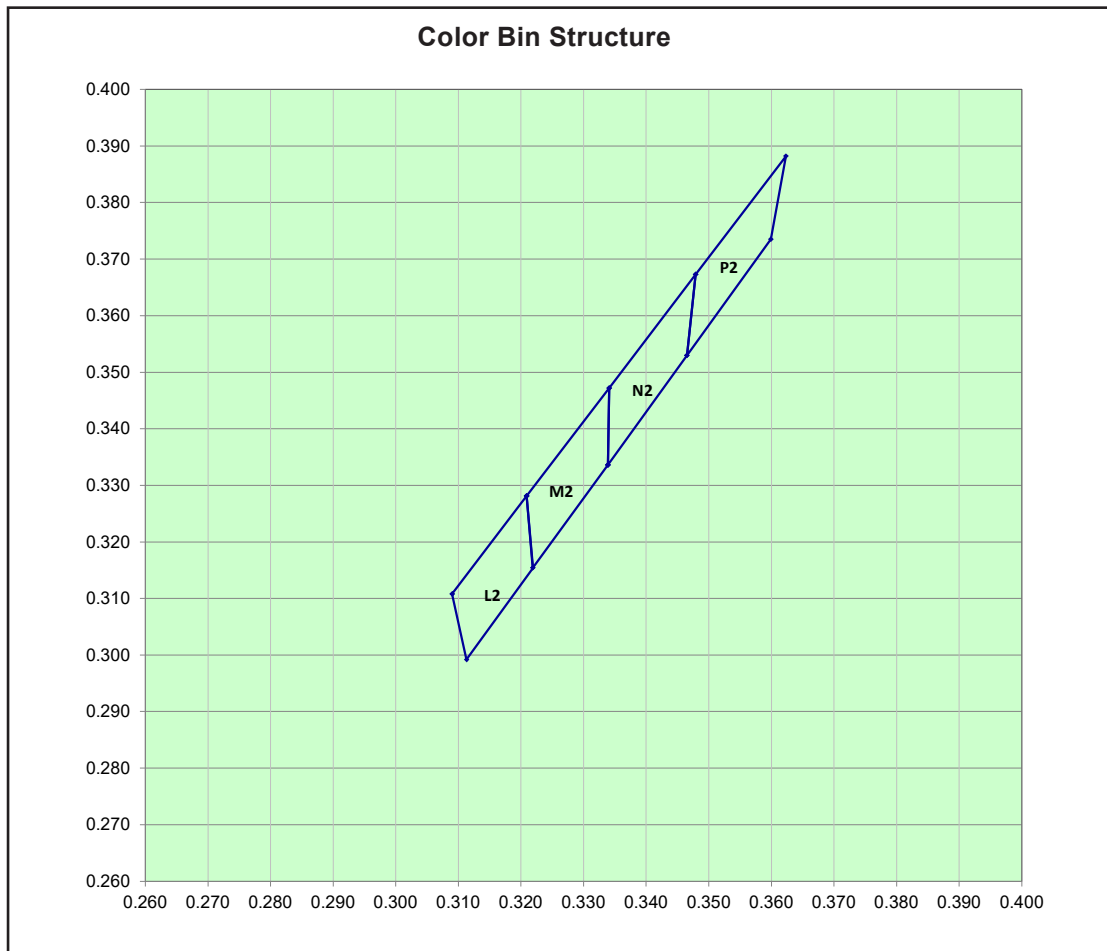

Bin		1	2	3	4
L2	Cx	0.3090	0.3113	0.3219	0.3209
	Cy	0.3108	0.2992	0.3154	0.3281
M2	Cx	0.3209	0.3219	0.3339	0.3341
	Cy	0.3281	0.3154	0.3336	0.3472
N2	Cx	0.3339	0.3341	0.3479	0.3465
	Cy	0.3336	0.3472	0.3673	0.3530
P2	Cx	0.3465	0.3479	0.3623	0.3599
	Cy	0.3530	0.3673	0.3882	0.3735

InGaN wavelength is very sensitive to drive current. Operating at lower current is not recommended and may yield unpredictable performance current pulsing should be used for dimming purposed.

MAW-SZHG-QS2-L1P2, Color Grouping *Appx. 2.1* (Not for New Design)

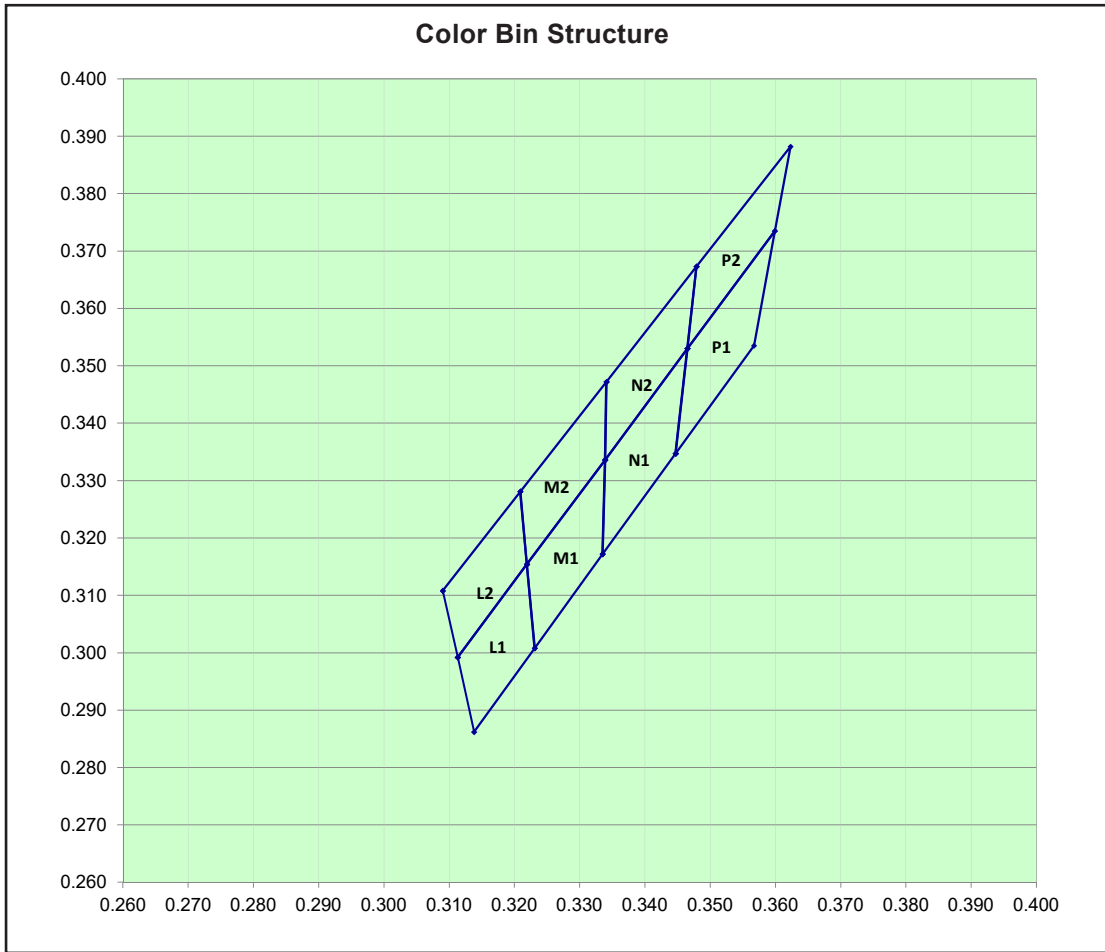

Bin		1	2	3	4
L1	Cx	0.3113	0.3138	0.3231	0.3219
	Cy	0.2992	0.2862	0.3008	0.3154
L2	Cx	0.3090	0.3113	0.3219	0.3209
	Cy	0.3108	0.2992	0.3154	0.3281
M1	Cx	0.3219	0.3231	0.3335	0.3339
	Cy	0.3154	0.3008	0.3172	0.3336
M2	Cx	0.3209	0.3219	0.3339	0.3341
	Cy	0.3281	0.3154	0.3336	0.3472
N1	Cx	0.3335	0.3339	0.3465	0.3447
	Cy	0.3172	0.3336	0.3530	0.3347
N2	Cx	0.3339	0.3341	0.3479	0.3465
	Cy	0.3336	0.3472	0.3673	0.3530
P1	Cx	0.3447	0.3465	0.3599	0.3567
	Cy	0.3347	0.3530	0.3735	0.3535
P2	Cx	0.3465	0.3479	0.3623	0.3599
	Cy	0.3530	0.3673	0.3882	0.3735

InGaN wavelength is very sensitive to drive current. Operating at lower current is not recommended and may yield unpredictable performance current pulsing should be used for dimming purposes.

Luminous Flux Group at Tj=25°C

Brightness Group	Luminous Flux (lm) <i>Appx. 1.2</i>
Q2	30.6 ... 34.8
Q3	34.8 ... 39.8
R2	39.8 ... 45.2
R3	45.2 ... 51.7
S2	51.7 ... 59.0
S3	59.0 ... 67.2

Vf Binning (Optional)

Vf Bin @ 150mA	Forward Voltage (V) <i>Appx. 3.1</i>
VM6	2.70 ... 3.00
VM7	3.00 ... 3.30
VM8	3.30 ... 3.60

Please consult sales and marketing for special part number to incorporate Vf binning.

Relative Luminous Flux Vs Forward Current

$\Phi_v/\Phi_v(150\text{mA}) = f(I_F); T_j = 25^\circ\text{C}$

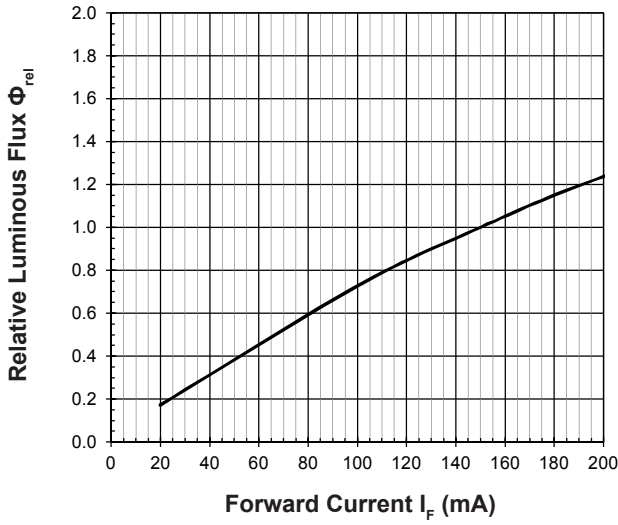

Forward Current Vs Forward Voltage

$I_F = f(V_F); T_j = 25^\circ\text{C}$

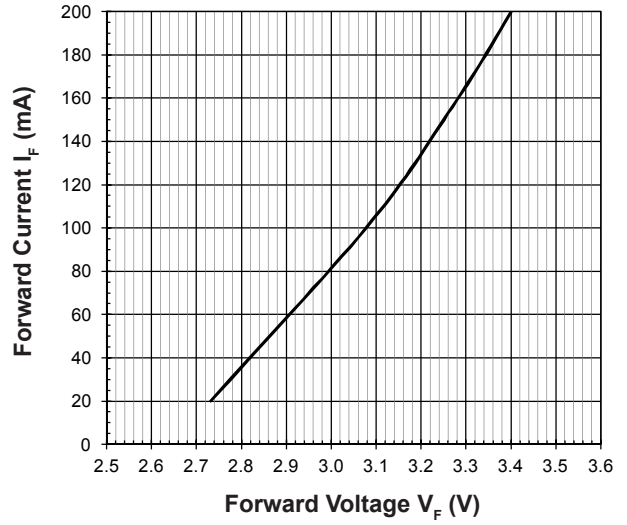

Maximum Current Vs Temperature

$I_F = f(T)$

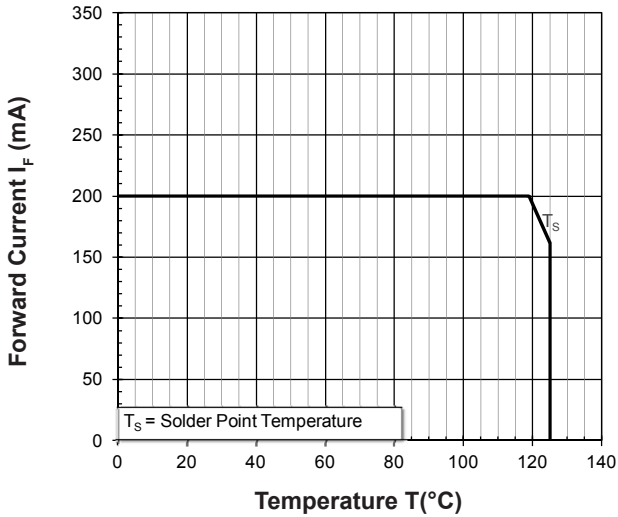

Relative Spectral Emission

$\Phi_{rel} = f(\lambda); T_j = 25^\circ\text{C}; I_F = 150\text{mA}$

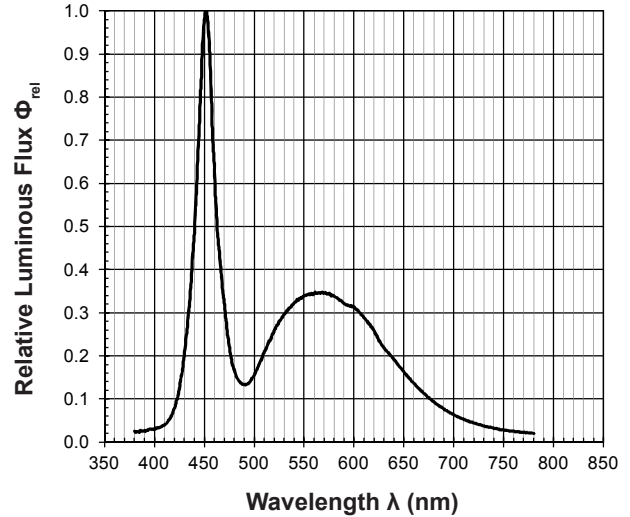

Chromaticity Coordinate Shift Vs Forward Current

$\Delta Cx, \Delta Cy = f(I_F); T_i = 25^\circ\text{C}$

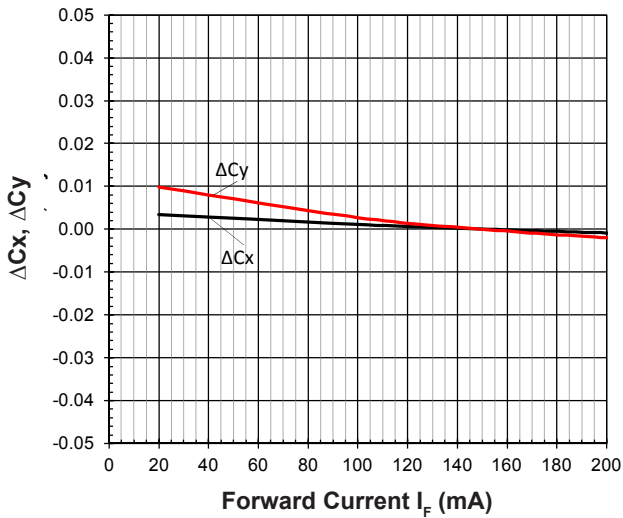

Allowable Forward Current Vs Duty Ratio

$(T_s = 55^\circ\text{C}; t_p \leq 100\mu\text{s})$



Radiation Pattern

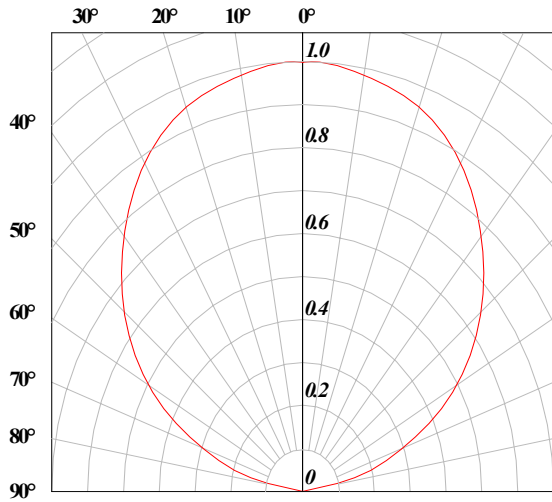

Forward Voltage Vs Junction Temperature

$$\Delta V_F = V_F - V_F(25^\circ\text{C}) = f(T_j); I_F = 150\text{mA}$$

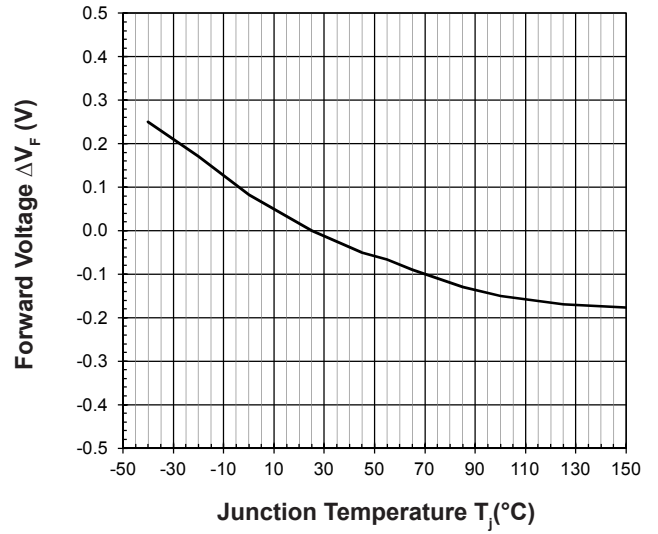

Relative Luminous Flux Vs Junction Temperature

$$\Phi_V/\Phi_V(25^\circ\text{C}) = f(T_j); I_F = 150\text{mA}$$

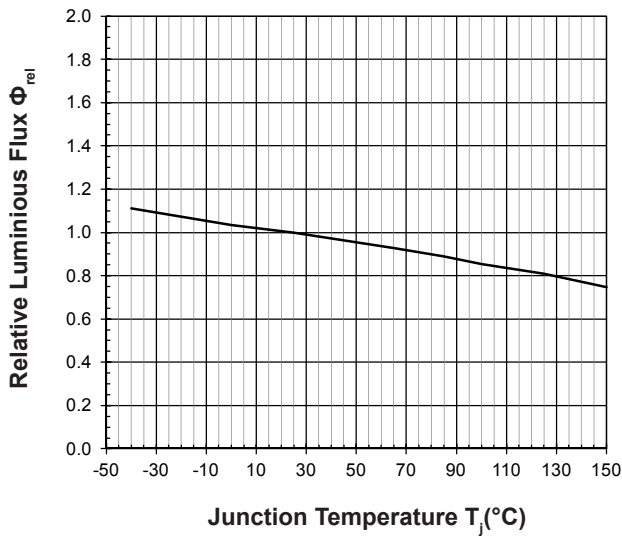

Chromaticity Coordinate Shift Vs Junction Temperature

$$\Delta C_x, \Delta C_y = f(T_j); I_F = 150\text{mA}$$

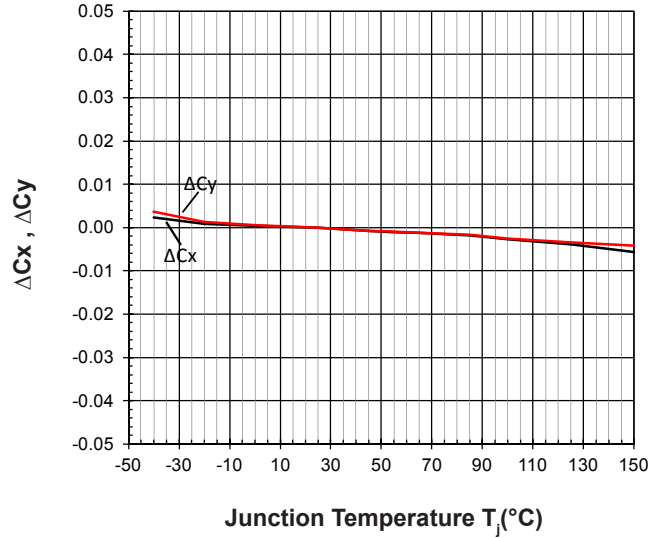

PrimaxPlus • InGaN : MAW-SZHG-L1P2 Package Outlines

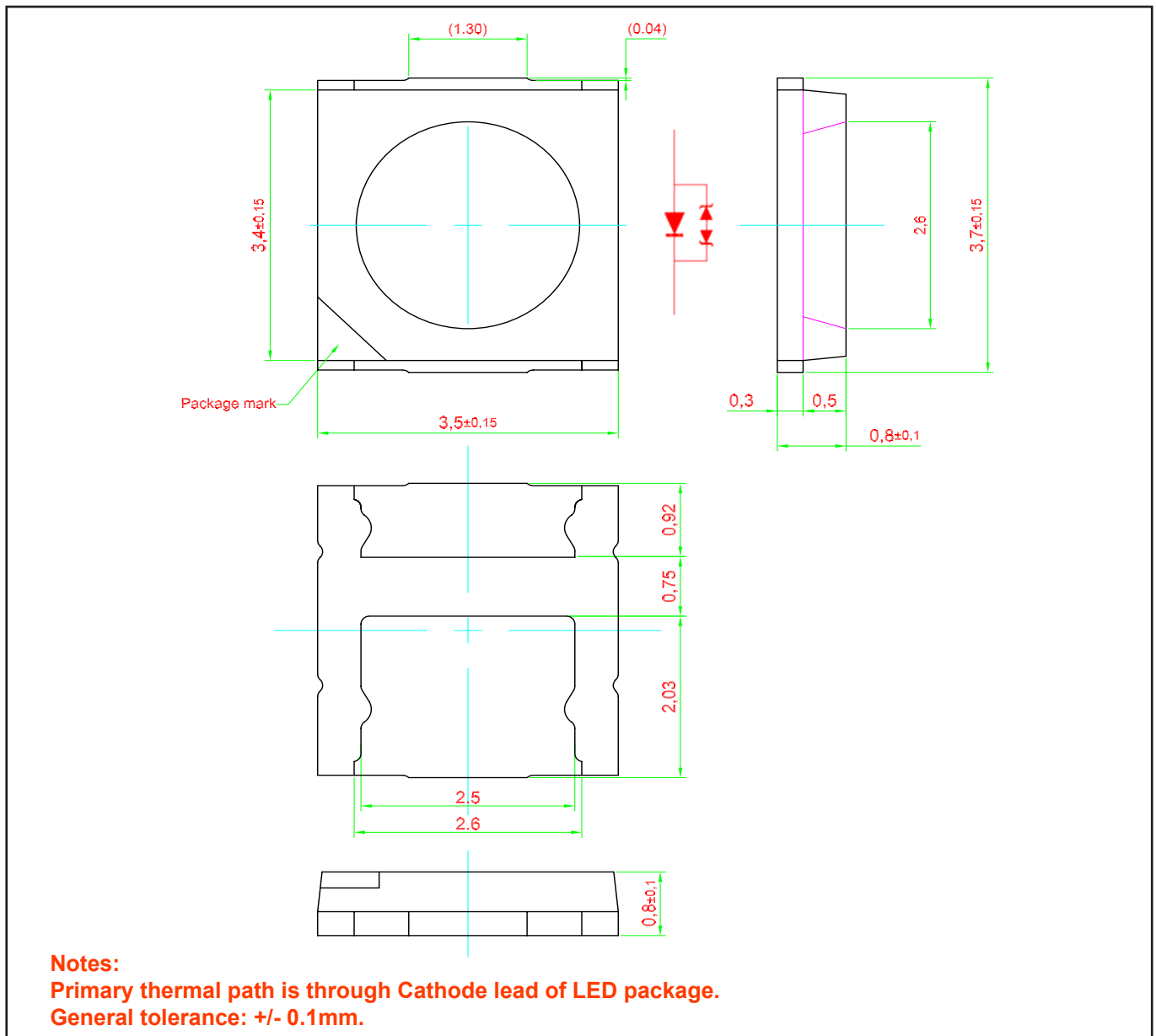

Material

Material	
Lead-frame	Cu Alloy With Au Plating
Package	High Temperature Resistant Plastic
Encapsulant	Silicone Resin
Soldering Leads	Au Plating

Recommended Solder Pad

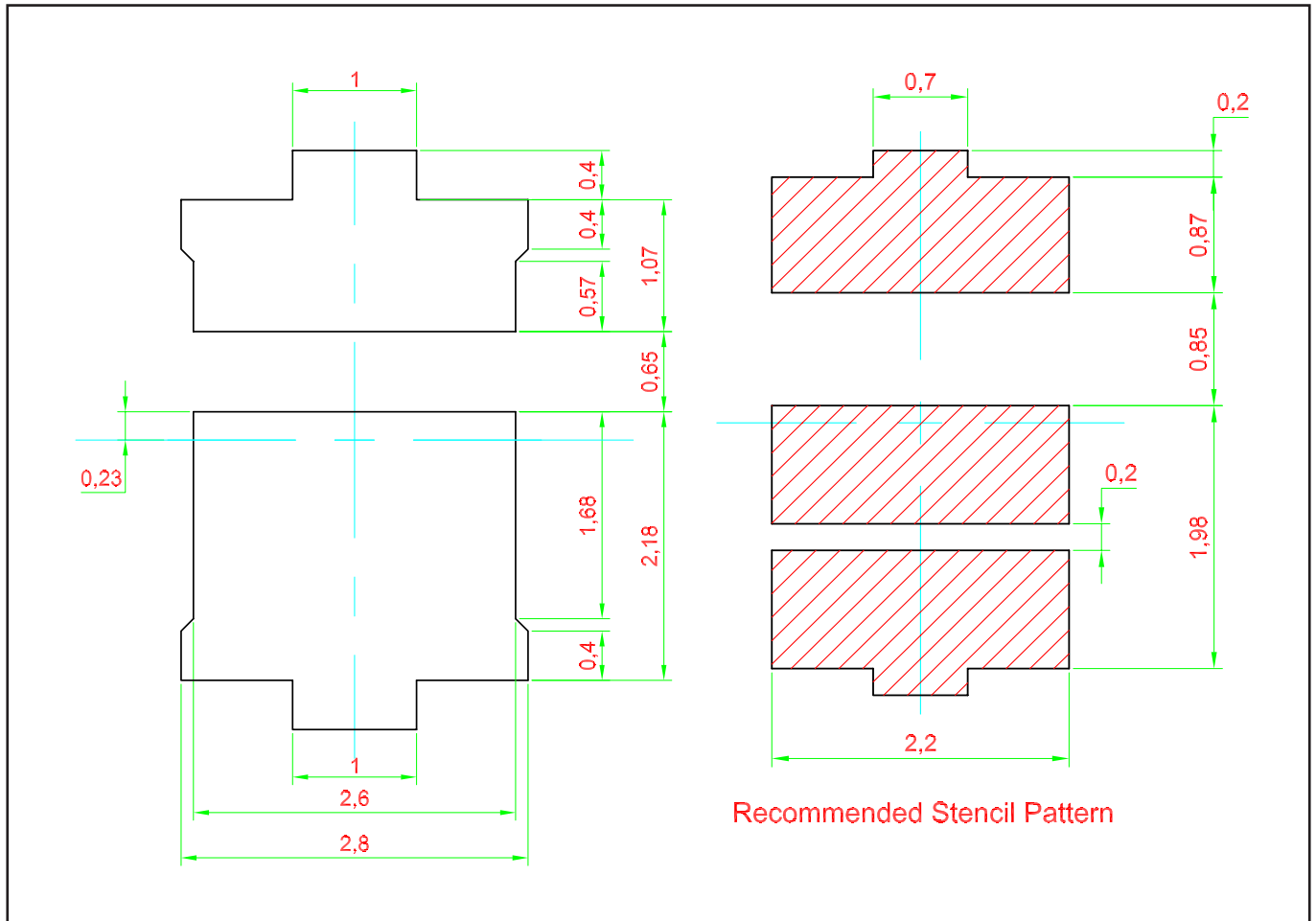

Taping and orientation

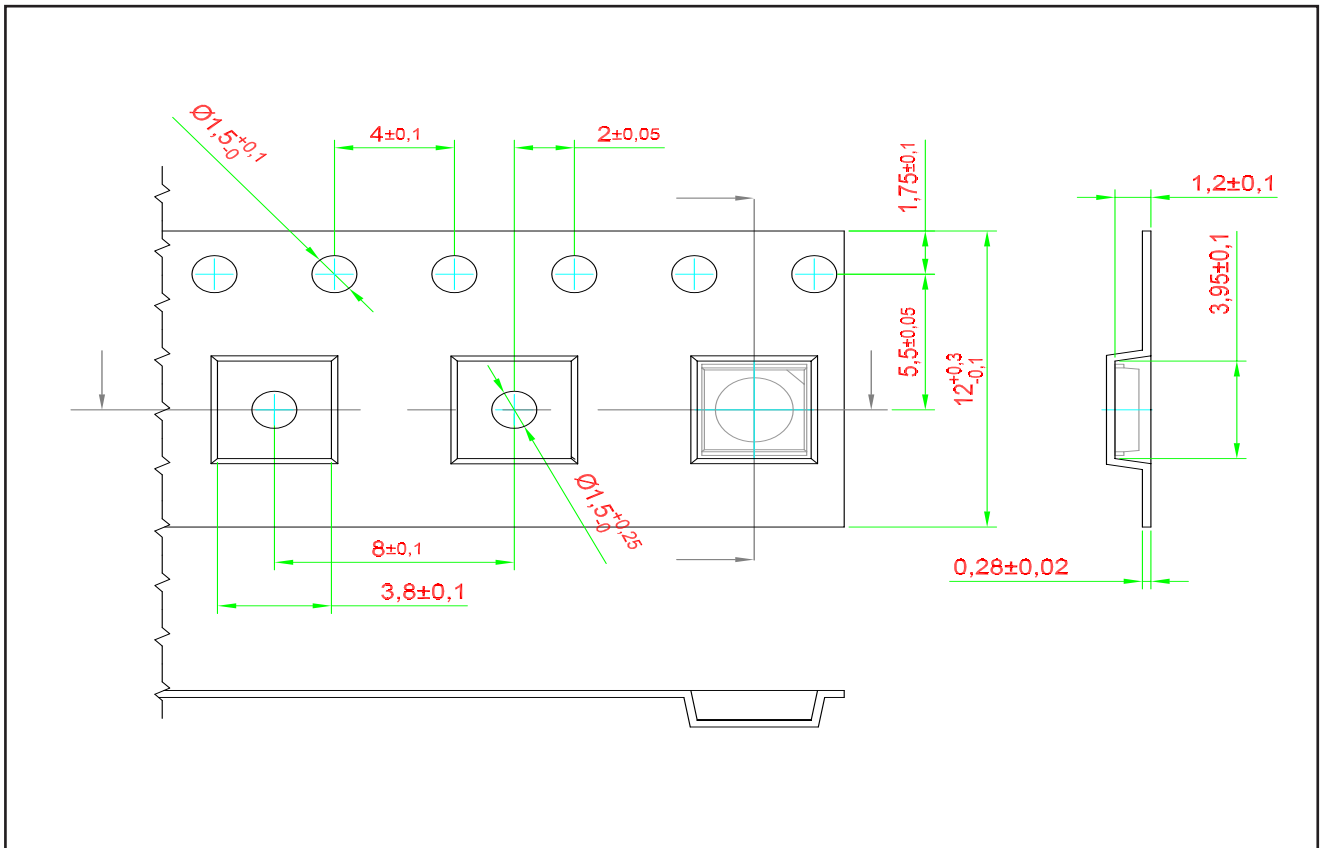

Packaging Specification

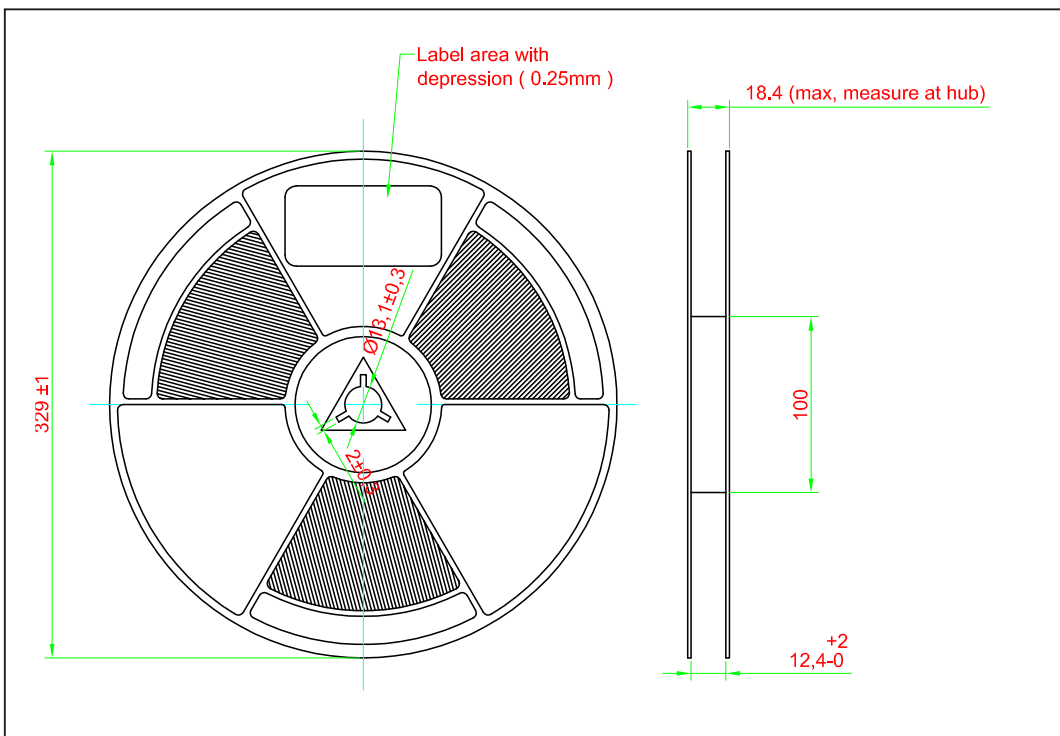
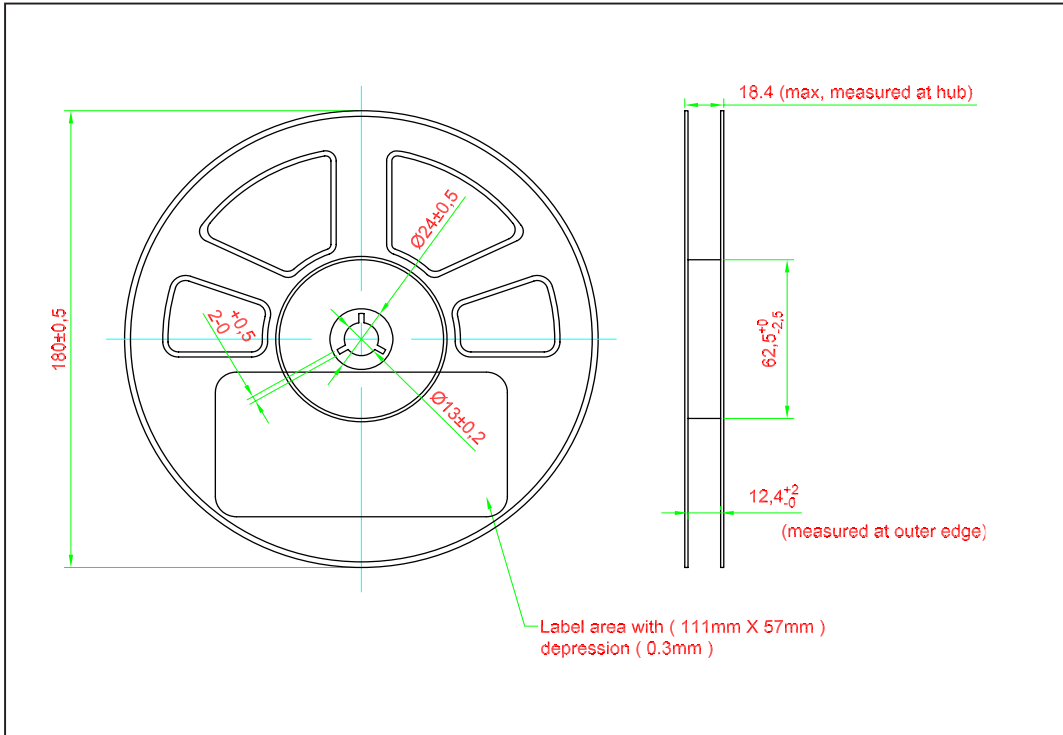

	Reel Diameter (mm)	Quantity (pcs)	*Ordering Number
Standard Packing	180	1500	MAW-SZHG-XXX-X
Optional Packing	329	5000	MAW-SZHG-XXX-X-5

Notes:

* For ordering purpose only. Please consult sales and marketing for details.

Packaging Specification

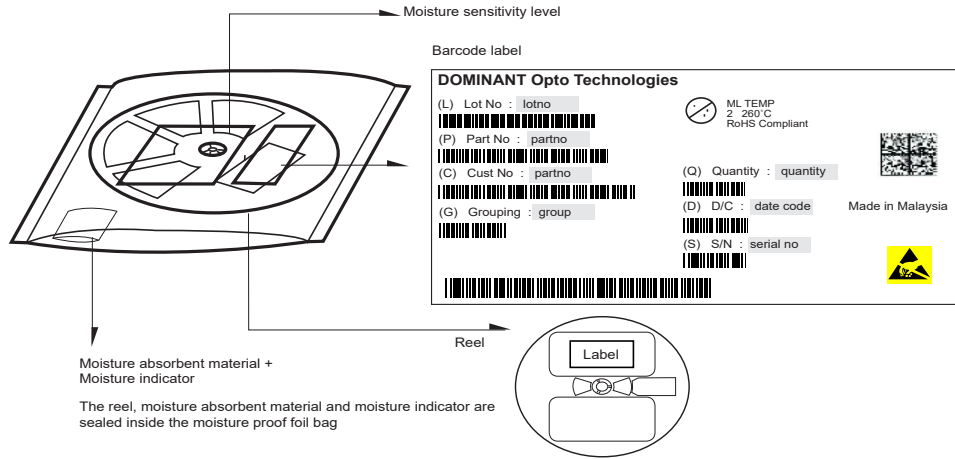

Quantity per bag (pcs)	Average 1pc PrimaxPlus (g)	1 completed bag (g)
1500	0.034	245 ± 10
5000	0.034	1150 ± 10

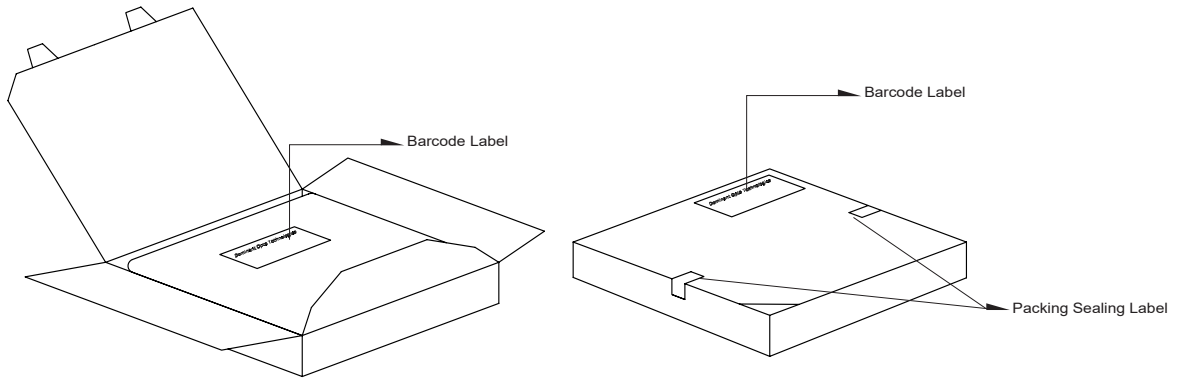

Reel Diameter (mm)	Packing Box Dimensions (mm)
180	210 x 210 x 20
329	345 x 345 x 20

Recommended Pb-free Soldering Profile

Product complies to MSL Level 2 acc. to JEDEC J-STD-020E

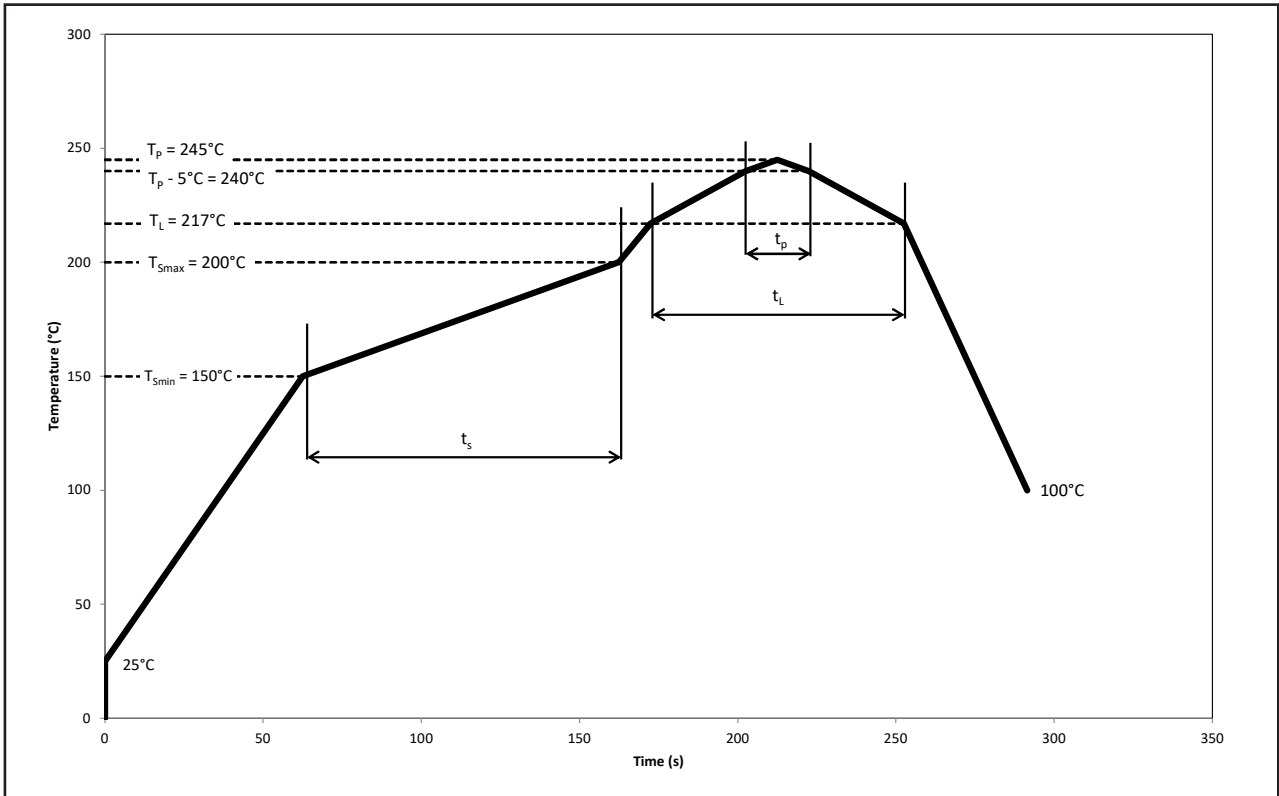

Profile Feature	Symbol	Pb-Free Assembly			Unit
		Min.	Recommended	Max.	
Ramp-up rate to preheat 25°C to T_{smin}	-	-	2	3	°C/s
Time t_s T_{smin} to T_{smax}	t_s	60	100	120	s
Ramp-up rate to peak T_L to T_p	-	-	2	3	°C/s
Liquidous temperature	T_L	-	217	-	°C
Time above liquidous temperature	t_L	60	80	150	s
Peak temperature	T_p	-	245	260	°C
Time within 5°C of the specified peak temperature $T_p - 5^\circ\text{C}$	t_p	10	20	30	s
Ramp-down rate T_p to 100°C	-	-	3	6	°C/s
Time 25°C to T_p	-	-	-	480	s

Appendix

1) **Brightness:**

- 1.1 Luminous intensity is measured at current pulse 25 ms(typ) with an internal reproducibility of $\pm 8\%$ and an expanded uncertainty of $\pm 11\%$ (according to GUM with a coverage factor of $k=3$).
- 1.2 Luminous flux is measured at current pulse 25 ms(typ) with an internal reproducibility of $\pm 8\%$ and an expanded uncertainty of $\pm 11\%$ (according to GUM with a coverage factor of $k=3$).
- 1.3 Radiant intensity is measured at current pulse 25 ms(typ) with an internal reproducibility of $\pm 8\%$ and an expanded uncertainty of $\pm 11\%$ (according to GUM with a coverage factor of $k=3$).
- 1.4 Radiant flux is measured at current pulse 25 ms(typ) with an internal reproducibility of $\pm 8\%$ and an expanded uncertainty of $\pm 11\%$ (according to GUM with a coverage factor of $k=3$).

2) **Color:**

- 2.1 Chromaticity coordinate groups are measured at current pulse 25 ms(typ) with an internal reproducibility of ± 0.005 and an expanded uncertainty of ± 0.01 (accordingly to GUM with a coverage factor of $k=3$).
- 2.2 Dominant wavelength is measured at current pulse 25 ms(typ) with an internal reproducibility of $\pm 0.5\text{nm}$ and an expanded uncertainty of $\pm 1\text{nm}$ (accordingly to GUM with a coverage factor of $k=3$).

3) **Voltage:**

- 3.1 Forward Voltage, V_f is measured when a current pulse of 8 ms(typ) with an internal reproducibility of $\pm 0.05\text{V}$ and an expanded uncertainty of $\pm 0.1\text{V}$ (accordingly to GUM with a coverage factor of $k=3$).

4) **Typical Values:**

- 4.1 At special conditions of LED manufacturing processes, typical data or calculated correlations of technical parameters only reflect the statistical figures. But not necessarily correspond to the actual parameters of each single product, which could differ from the typical data or calculated correlations or the typical characteristic line. These typical data may change whenever technical improvements happen.

5) **Tolerance of Measure**

- 5.1 Unless otherwise noted in drawing, tolerances are specified with ± 0.1 and dimension are specific in mm.

Revision History

Page	Subjects	Date of Modification
-	Initial Release	29 Mar 2018
6, 13	Update Graph: Relative Forward Voltage Vs Junction Temperature Relative Luminous Flux Vs Junction Temperature Chromaticity Coordinate Shift Vs Junction Temperature Update Appendix	29 Mar 2018
5, 10, 11, 15	Update Graph: - Chromaticity Coordinate Shift Vs Forward Current Update Packaging Specification	20 Sep 2019
1, 2, 5	Update Features: AEC-Q101 to AEC-Q102 Update Peak Pulse Current Test Condition Update Graph: Allowable Forward Current Vs Duty Ratio	12 May 2020
2, 13	Not for New Design: MAW-SZHG-QS2-L1P2 Update Recommended Pb-free Soldering Profile	16 June 2021
2	Add New Partno: MAW-SZHG-Q3S-L2P2	25 Oct 2022
11, 12	Update Quantity per Reel: 1000pcs to 1500pcs	26 Oct 2023

NOTE

All the information contained in this document is considered to be reliable at the time of publishing. However, DOMINANT Opto Technologies does not assume any liability arising out of the application or use of any product described herein.

DOMINANT Opto Technologies reserves the right to make changes to any products in order to improve reliability, function or design.

DOMINANT Opto Technologies products are not authorized for use as critical components in life support devices or systems without the express written approval from the Managing Director of DOMINANT Opto Technologies.

Dispose of product is in accordance with local, regional, national and international regulations.

About Us

DOMINANT Opto Technologies is a dynamic company that is amongst the world's leading automotive LED manufacturers. With an extensive industry experience and relentless pursuit of innovation, DOMINANT's state-of-art manufacturing and development capabilities have become a trusted and reliable brand across the globe. More information about DOMINANT Opto Technologies, an IATF 16949 and ISO 14001 certified company, can be found under <http://www.dominant-semi.com>.

Please contact us for more information:

DOMINANT Opto Technologies Sdn. Bhd
Lot 6, Batu Berendam, FTZ Phase III, 75350 Melaka, Malaysia.
Tel: +606 283 3566 Fax: +606 283 0566
E-mail: sales@dominant-semi.com
