

SpicePlus

Like spice, its diminutive size is a stark contrast to its standout performance in terms of brightness, durability and reliability. Despite being the smallest in size yet the SpicePlus packs a powerful performance and is a highly reliable design device.



Features:

- > Super high brightness surface mount LED automotive exterior applications.
- > 120° viewing angle.
- > Compact package outline (LxW) of 2.5 x 2.0mm.
- > Ultra low height profile - 0.7mm.
- > Low thermal resistance.
- > Superior corrosion robustness.
- > Compatible to IR reflow soldering.
- > Compliance to automotive standard; AEC-Q102.
- > Environmental friendly; RoHS compliance.

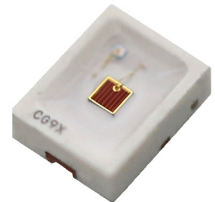

Applications:

- > Automotive: Exterior application: eg: Turn Signal, Rear Combination Light (RCL), Center High Mounted Stop Light (CHMSL).

Electrical Characteristics at Tj=25°C

Part Number	Color	Viewing Angle°	Luminous Flux @ 200mA (lm) <i>Appx. 1.2</i>		
			Min.	Typ.	Max.
● SPS-VZHG-MN3-3	Super Red, 635 nm	120	13.9	18.1	23.5
● SPS-VZHG-NP3-2	Super Red, 630 nm	120	18.1	23.5	30.6
● SPA-VZHG-PQ3-4	Amber, 624 nm	120	23.5	30.6	39.8
● SPA-VZHG-QR3-2	Amber, 615 nm	120	30.6	39.8	51.7
● SPY-VZHG-N3Q-1	Yellow, 589 nm	120	20.6	26.8	39.8
● Not for new design					

Electrical Characteristics at Tj=25°C

Part Number	Vf @ If = 200mA <i>Appx. 3.1</i>		
	Min. (V)	Typ. (V)	Max. (V)
SPx-VZHG	1.9	2.3	2.6

Absolute Maximum Ratings

	Maximum Value	Unit
DC forward current	250	mA
Peak pulse current; (Ts = 55°C, tp ≤ 100µs, Duty cycle = 0.03)	600	mA
Reverse voltage; Ir _{max} = 10µA	Not designed for reverse bias	V
ESD threshold (HBM)	8	KV
LED junction temperature	150	°C
Operating temperature	-40 ... +125	°C
Storage temperature	-40 ... +125	°C
Thermal resistance		
- Real Thermal Resistance		
Junction / solder point, R _{th JS real} (typ = 28)	35	K/W
- Electrical Thermal Resistance		
Junction / solder point, R _{th JS el} (typ = 20)	25	K/W

Wavelength Grouping at Tj= 25°C

Color	Group	Wavelength distribution (nm) <i>Appx. 2.2</i>
SPx; Super Red	Full	627 - 637
	W	627 - 630
	X	630 - 634
	Y	634 - 637
SPx; Amber	Full	612 - 627
	W	612 - 616
	X	616 - 620
	Y	620 - 624
	Z	624 - 627
SPx; Yellow	Full	586 - 595
	X	586 - 589
	Y	589 - 592
	Z	592 - 595

Luminous Flux Group at Tj=25°C

Brightness Group	Luminous Flux <i>Appx. 1.2</i> (lm)
M2	13.9 ... 15.8
M3	15.8 ... 18.1
N2	18.1 ... 20.6
N3	20.6 ... 23.5
P2	23.5 ... 26.8
P3	26.8 ... 30.6
Q2	30.6 ... 34.8
Q3	34.8 ... 39.8
R2	39.8 ... 45.2
R3	45.2 ... 51.7

Vf Bining (Optional)

Vf Bin @ 200 mA	Forward Voltage (V) <small>Appx. 4.1</small>
V43	1.90 ... 2.05
V44	2.05 ... 2.20
V45	2.20 ... 2.35
V46	2.35 ... 2.50
V47	2.50 ... 2.65

Please consult sales and marketing for special part number to incorporate Vf binning.

Relative Luminous Flux Vs Forward Current

$\Phi_{rel}/\Phi_{rel}(200mA) = f(I_F); T_j = 25^\circ C$

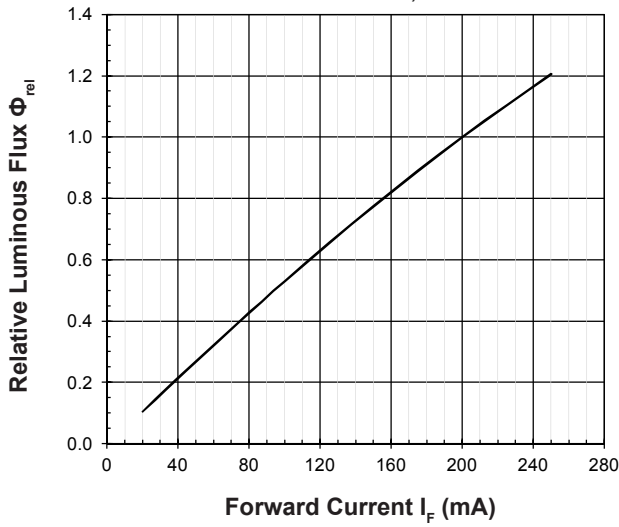

Forward Current Vs Forward Voltage

$I_F = f(V_F); T_j = 25^\circ C$

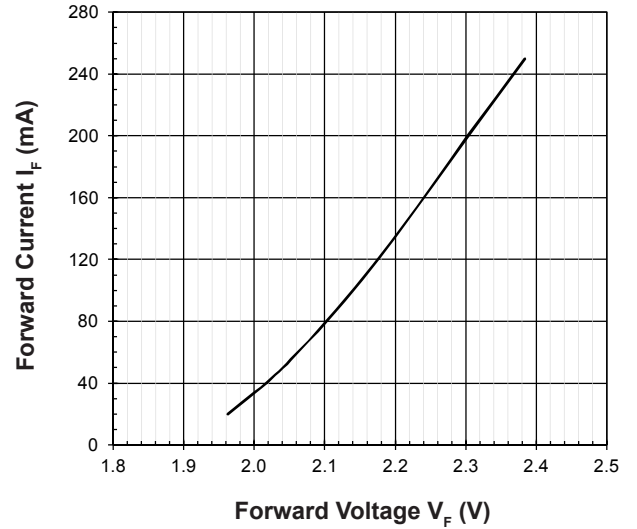

Maximum Current Vs Temperature

$I_F = f(T)$

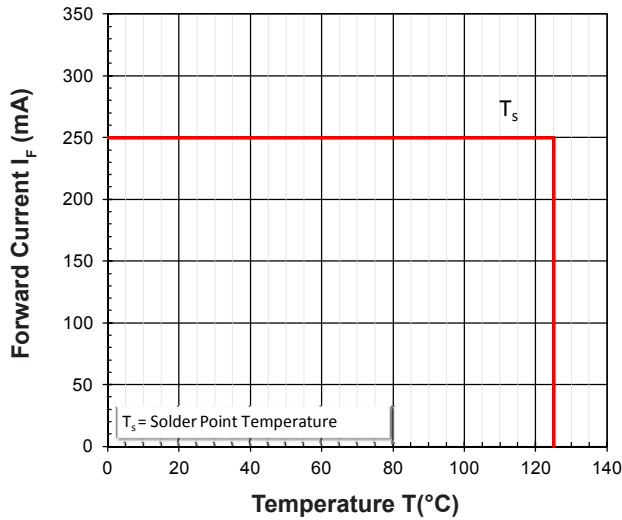

Relative Spectral Emission

$\Phi_{rel} = f(\lambda); T_j = 25^\circ C; I_F = 200mA$

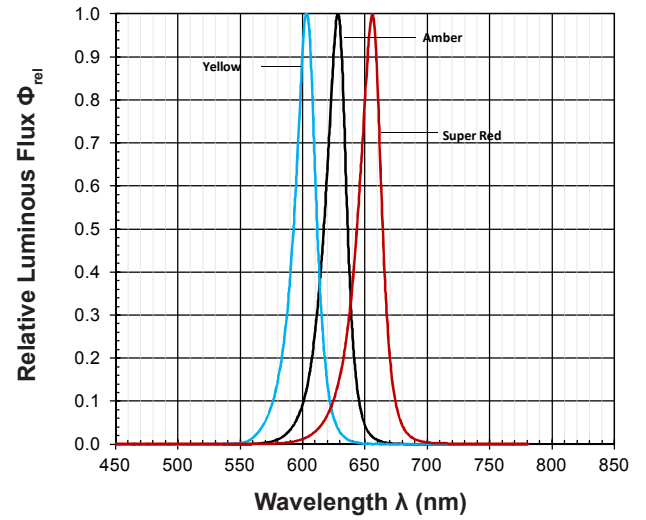

Allowable Forward Current Vs Duty Ratio

$(T_s = 55^\circ C; t_p \le 10\mu s)$

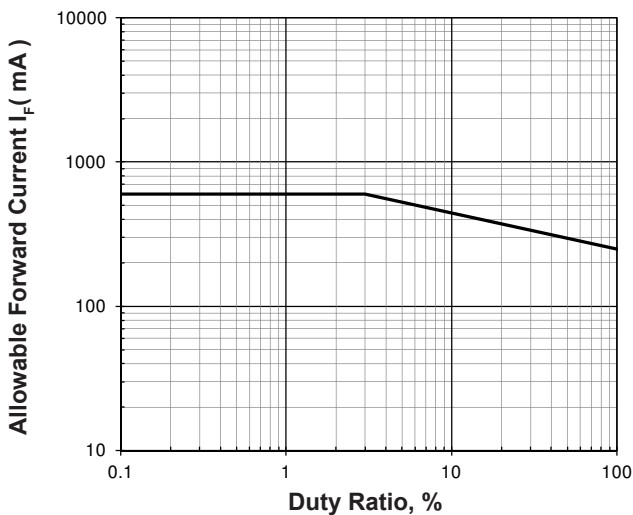

Radiation Pattern

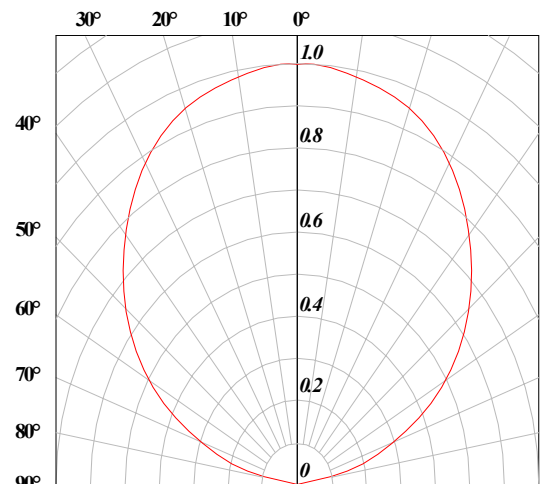

Forward Voltage Vs Junction Temperature

$$\Delta V_F = V_F - V_F(25^\circ\text{C}) = f(T_j); I_F = 200\text{mA}$$

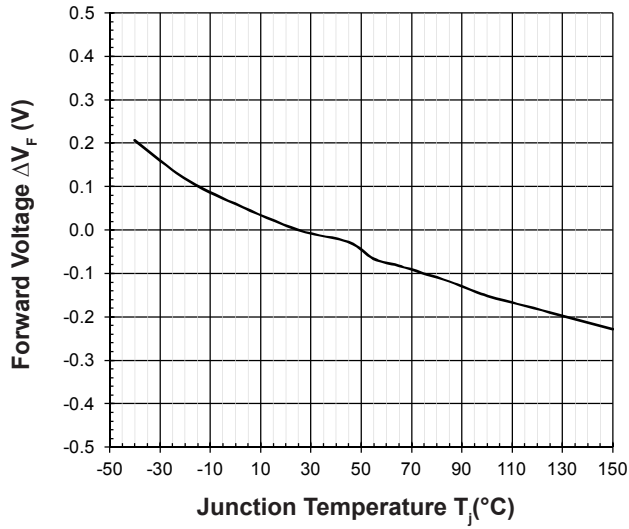

Relative Luminous Flux Vs Junction Temperature

$$\Phi_V/\Phi_V(25^\circ\text{C}) = f(T_j); I_F = 200\text{mA}$$

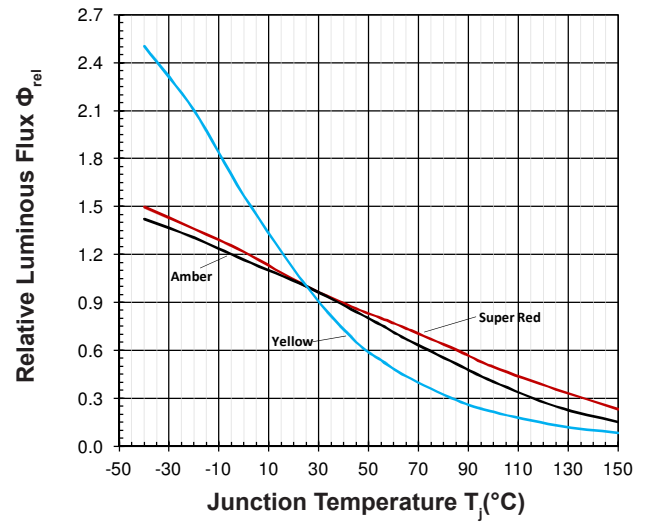

Wavelength Vs Junction Temperature

$$\Delta \lambda_{\text{dom}} = \lambda_{\text{dom}} - \lambda_{\text{dom}}(25^\circ\text{C}) = f(T_j); I_F = 200\text{mA}$$

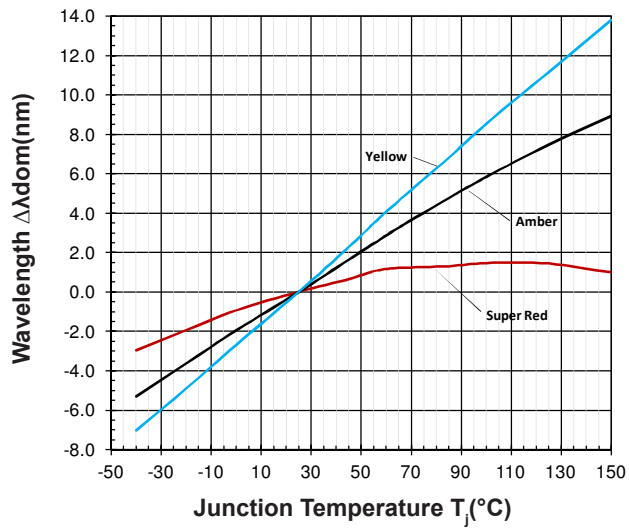

SpicePlus 2520 AllnGaP : SPx-VZHG Package Outlines

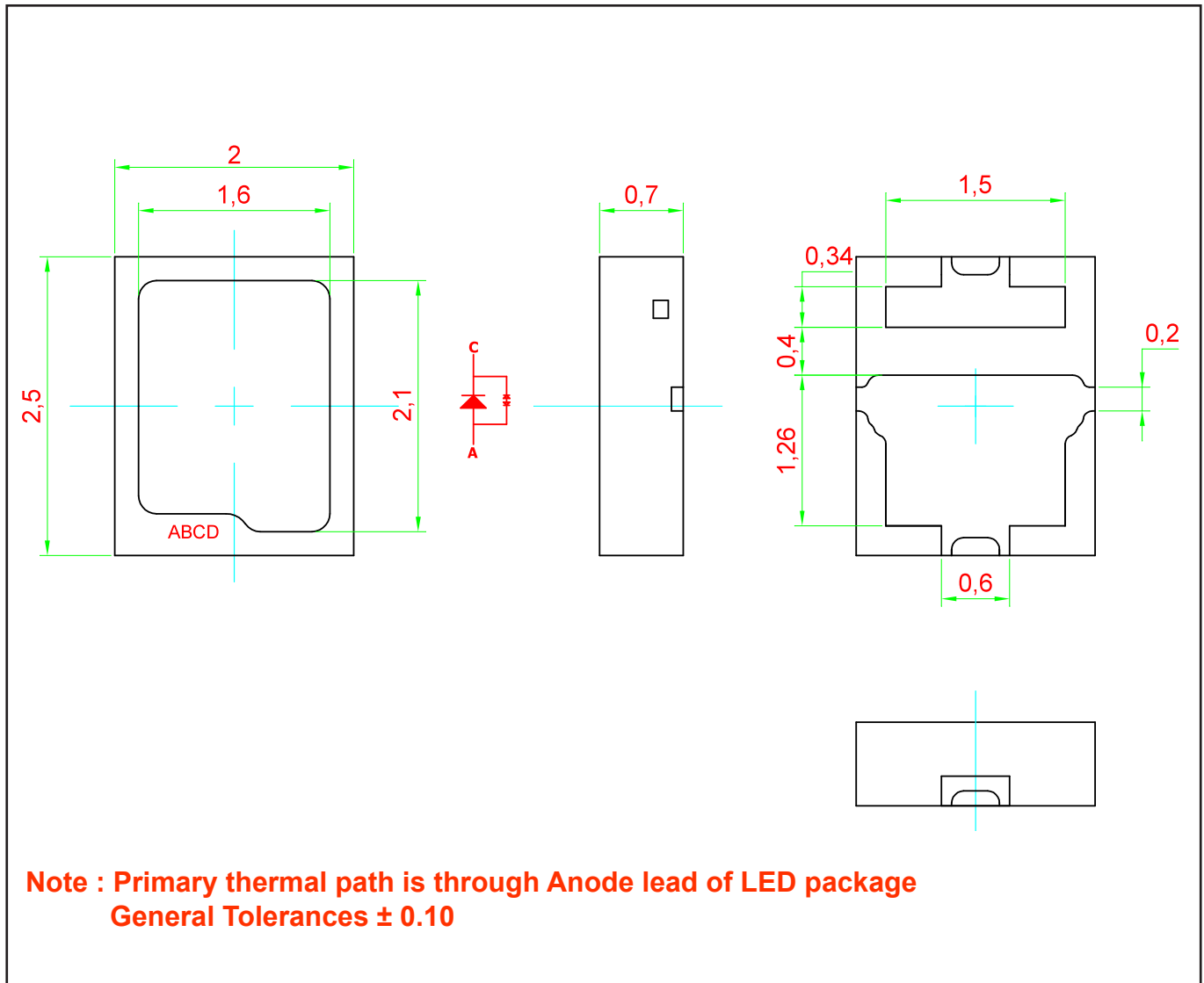

Material

	Material
Lead-frame	Cu Alloy With Au Plating
Package	Heat Resistant Polymer
Encapsulant	Silicone Resin
Soldering Leads	Au Plating

Recommended Solder Pad

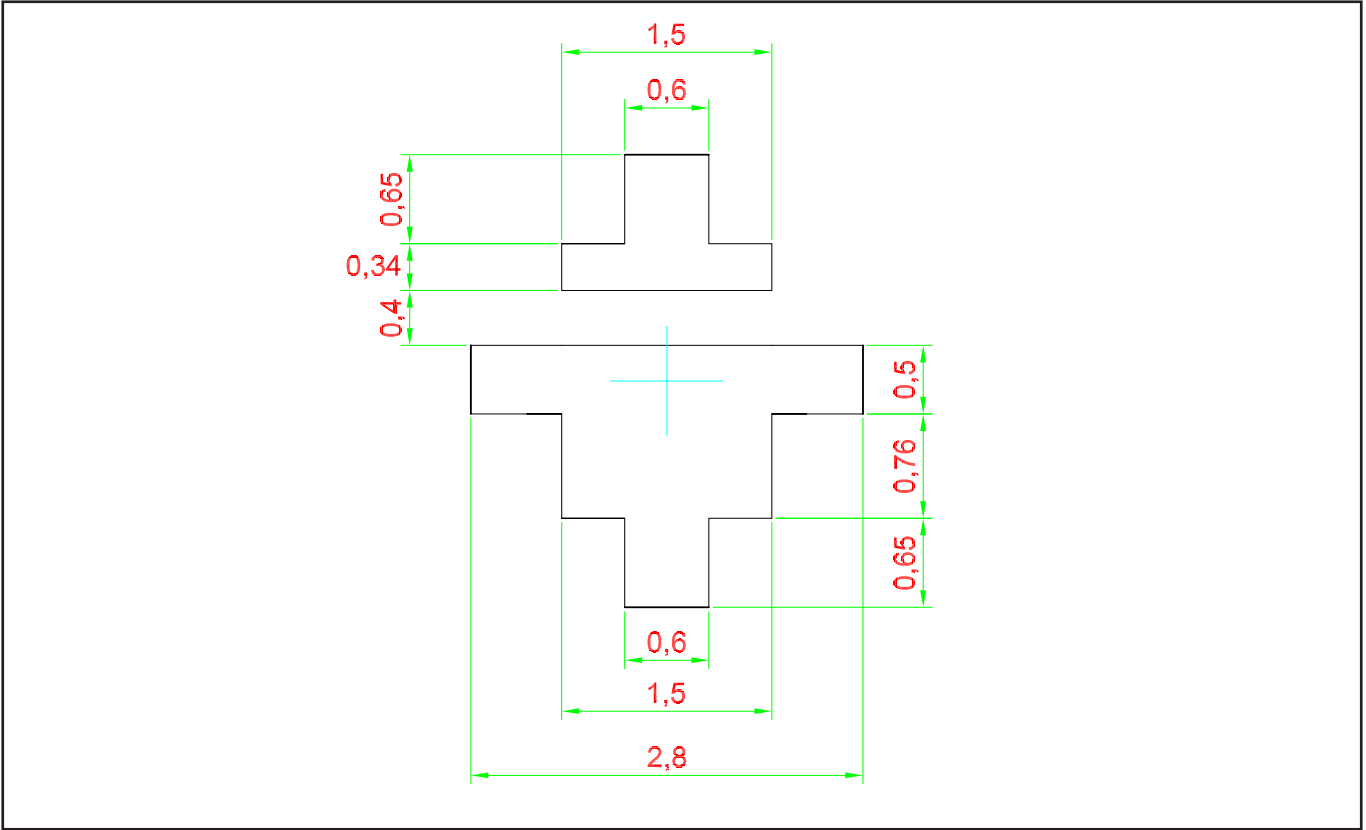

Recommended Solder Stencil Design

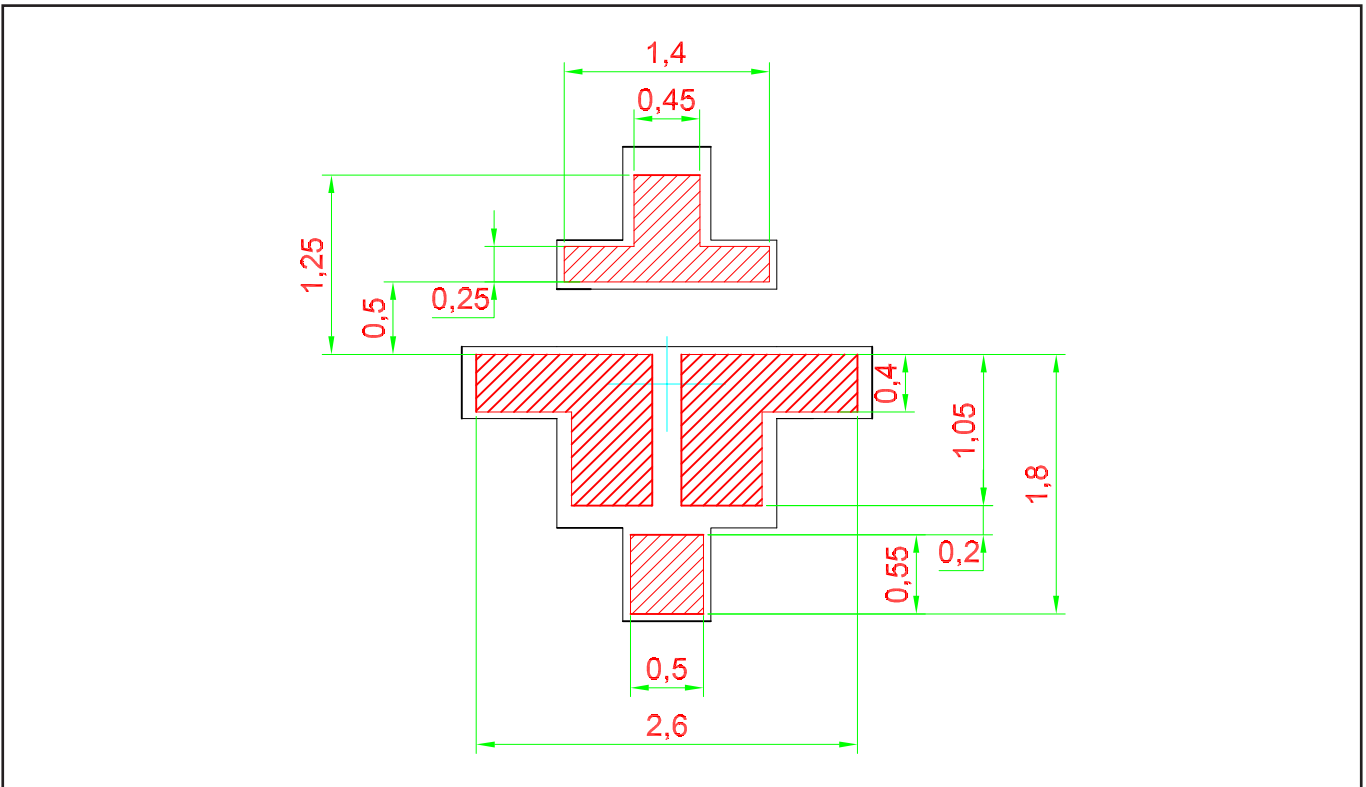

Taping and orientation

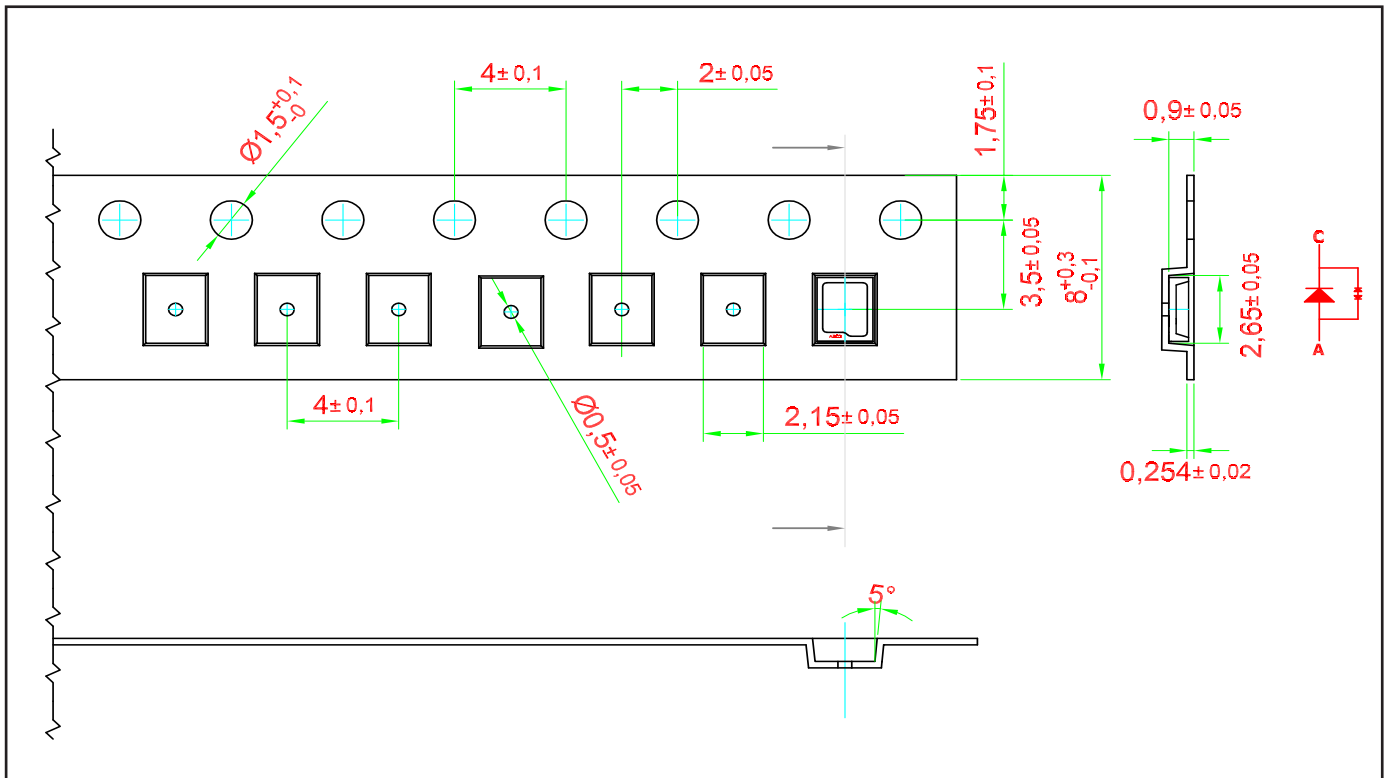

Packaging Specification

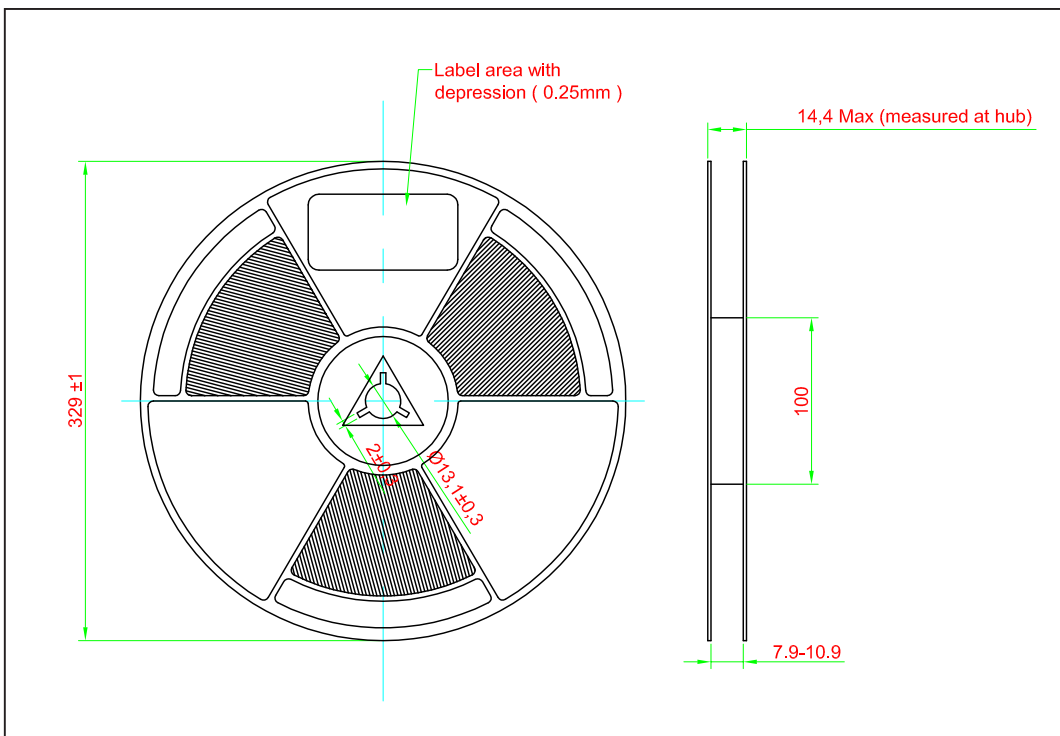
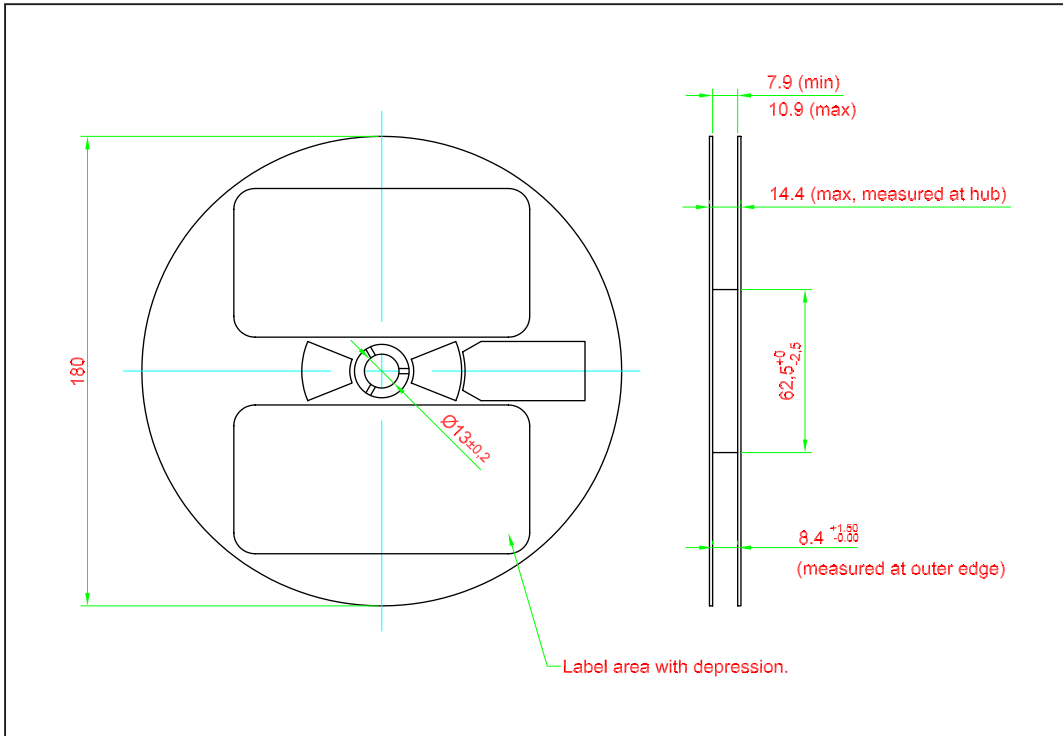

	Reel Diameter (mm)	Quantity (pcs)	*Ordering Number
Standard Packing	180	4000	SPx-VZHG-xxx-x
Optional Packing	329	15000	SPx-VZHG-xxx-x-L

Notes:

* For ordering purpose only. Please consult sales and marketing for details.

Packaging Specification

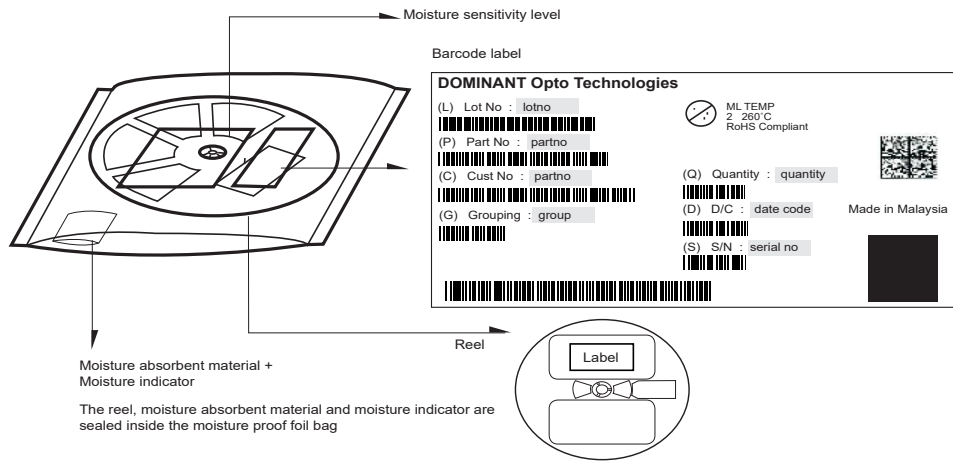

Quantity per bag (pcs)	Average 1pc SpicePlus 2520 (g)	1 completed bag (g)
4000	0.011	200 ± 10
15000	0.011	600 ± 10

Recommended Pb-free Soldering Profile

Product complies to MSL Level 2 acc. to JEDEC J-STD-020E

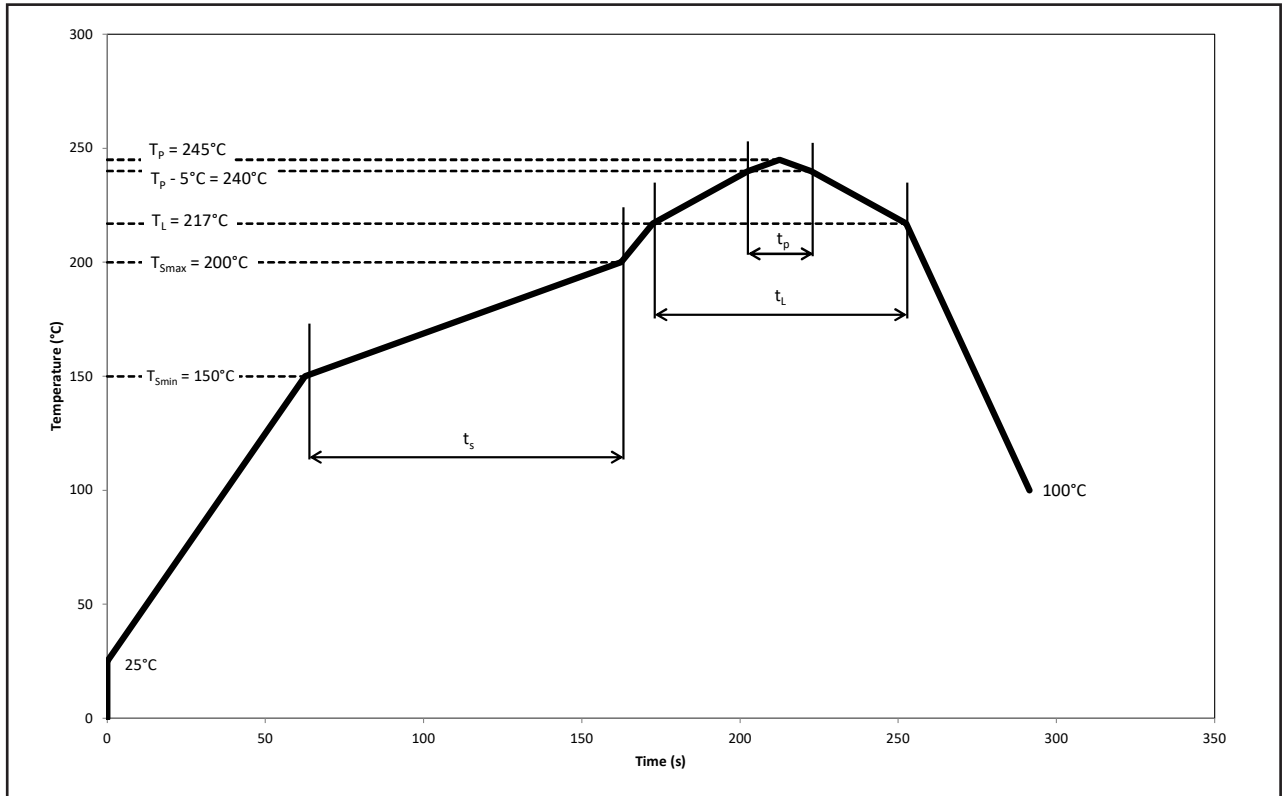

Profile Feature	Symbol	Pb-Free Assembly			Unit
		Min.	Recommended	Max.	
Ramp-up rate to preheat 25°C to T_{smin}	-	-	2	3	°C/s
Time t_s T_{smin} to T_{smax}	t_s	60	100	120	s
Ramp-up rate to peak T_L to T_p	-	-	2	3	°C/s
Liquidous temperature	T_L	-	217	-	°C
Time above liquidous temperature	t_L	60	80	150	s
Peak temperature	T_p	-	245	260	°C
Time within 5°C of the specified peak temperature $T_p - 5^\circ\text{C}$	t_p	10	20	30	s
Ramp-down rate T_p to 100°C	-	-	3	6	°C/s
Time 25°C to T_p	-	-	-	480	s

Appendix

1) **Brightness:**

- 1.1 Luminous intensity is measured at current pulse 25 ms(typ) with an internal reproducibility of $\pm 8\%$ and an expanded uncertainty of $\pm 11\%$ (according to GUM with a coverage factor of $k=3$).
- 1.2 Luminous flux is measured at current pulse 25 ms(typ) with an internal reproducibility of $\pm 8\%$ and an expanded uncertainty of $\pm 11\%$ (according to GUM with a coverage factor of $k=3$).
- 1.3 Radiant intensity is measured at current pulse 25 ms(typ) with an internal reproducibility of $\pm 8\%$ and an expanded uncertainty of $\pm 11\%$ (according to GUM with a coverage factor of $k=3$).
- 1.4 Radiant flux is measured at current pulse 25 ms(typ) with an internal reproducibility of $\pm 8\%$ and an expanded uncertainty of $\pm 11\%$ (according to GUM with a coverage factor of $k=3$).

2) **Color:**

- 2.1 Chromaticity coordinate groups are measured at current pulse 25 ms(typ) with an internal reproducibility of ± 0.005 and an expanded uncertainty of ± 0.01 (accordingly to GUM with a coverage factor of $k=3$).
- 2.2 Dominant wavelength is measured at current pulse 25 ms(typ) with an internal reproducibility of $\pm 0.5\text{nm}$ and an expanded uncertainty of $\pm 1\text{nm}$ (accordingly to GUM with a coverage factor of $k=3$).

3) **Voltage:**

- 3.1 Forward Voltage, V_f is measured when a current pulse of 8 ms(typ) with an internal reproducibility of $\pm 0.05\text{V}$ and an expanded uncertainty of $\pm 0.1\text{V}$ (accordingly to GUM with a coverage factor of $k=3$).

4) **Typical Values:**

- 4.1 At special conditions of LED manufacturing processes, typical data or calculated correlations of technical parameters only reflect the statistical figures. But not necessarily correspond to the actual parameters of each single product, which could differ from the typical data or calculated correlations or the typical characteristic line. These typical data may change whenever technical improvements happen.

5) **Tolerance of Measure**

- 5.1 Unless otherwise noted in drawing, tolerances are specified with ± 0.1 and dimension are specific in mm.

Revision History

Page	Subjects	Date of Modification
-	Initial Release	10 Aug 2017
2, 5	Typo Error on DC Forward Current Error on Graph	07 Sep 2017
6	Update Graph: Relative Luminous Flux Vs Junction Temperature	17 Jan 2018
5, 11, 13	Update Graph: Forward Current Vs Forward Voltage Update Packaging Specification Update Appendix	08 May 2018
1, 2, 5	Update Features Update Absolute Maximum Ratings Update Graph: Allowable Forward Current Vs Duty Ratio	26 Nov 2019
2, 12	Not for New Design: SPS-VZHG-MN3-3, SPS-VZHG-NP3-2, SPA-VZHG-PQ3-4, SPA-VZHG-QR3-2, SPY-VZHG-N3Q-1 Update Recommended Pb-free Soldering Profile	16 Dec 2020
10, 11	Update Packaging Specification	05 Apr 2022
10, 11	Update Quantity per Reel: 2000pcs to 4000pcs	27 Nov 2023
1, 7, 11	Update Product Photo Update Package Outline Update Packaging Specification	03 Apr 2024

NOTE

All the information contained in this document is considered to be reliable at the time of publishing. However, DOMINANT Opto Technologies does not assume any liability arising out of the application or use of any product described herein.

DOMINANT Opto Technologies reserves the right to make changes to any products in order to improve reliability, function or design.

DOMINANT Opto Technologies products are not authorized for use as critical components in life support devices or systems without the express written approval from the Managing Director of DOMINANT Opto Technologies.

Dispose of product is in accordance with local, regional, national and international regulations.

About Us

DOMINANT Opto Technologies is a dynamic company that is amongst the world's leading automotive LED manufacturers. With an extensive industry experience and relentless pursuit of innovation, DOMINANT's state-of-art manufacturing and development capabilities have become a trusted and reliable brand across the globe. More information about DOMINANT Opto Technologies, an IATF 16949 and ISO 14001 certified company, can be found under <http://www.dominant-semi.com>.

Please contact us for more information:

DOMINANT Opto Technologies Sdn. Bhd
Lot 6, Batu Berendam, FTZ Phase III, 75350 Melaka, Malaysia.
Tel: +606 283 3566 Fax: +606 283 0566
E-mail: sales@dominant-semi.com